

TECHNICAL MANUAL

**OPERATOR, ORGANIZATIONAL,
DIRECT SUPPORT, AND GENERAL
SUPPORT MAINTENANCE MANUAL
(INCLUDING REPAIR PARTS)**

FOR

**8447A AMPLIFIER/DUAL AMPLIFIER
.1-400MHz**

(PATRIOT AIR DEFENSE GUIDED MISSILE SYSTEM)

HEADQUARTERS, DEPARTMENT OF THE ARMY

NOVEMBER 1986

WARNING

DANGEROUS VOLTAGE

is used to operate this equipment

DEATH ON CONTACT

may result if safety precautions are not observed.

Never work on electronic equipment unless there is someone nearby who is familiar with the operation and hazards of the equipment and is able to give first aid. When the technician is aided by operators, he must warn them about dangerous areas.

When possible, shut off power to equipment before beginning work on equipment. Ground every capacitor likely to hold a dangerous potential. When working inside equipment, after the power has been turned off, always ground every part before touching it.

Be careful not to contact high-voltage connections when installing or operating this equipment.

When possible, keep one hand away from equipment to reduce the hazard of current flowing through the vital organs of the body.

Read FM 21-11, First Aid for Soldiers, and learn how to administer artificial respiration.

WARNING

Do not be misled by the term "low voltage." Under adverse conditions, potentials as low as 50 volts may cause death.

a/(b blank)

TABLE OF CONTENTS

<u>Section</u>		<u>Page</u>
Section 0	General	
0-1	Maintenance Forms and Records	0-1
0-2	Reporting Equipment Improvement Recommendations (EIR)	0-1
0-3	Administrative Storage	0-1
0-4	Destruction of Army Material to Prevent Enemy Use.....	0-1
Section I	General Information.....	
1-1	Introduction.....	1-1
1-4	Instrument Covered by Manual	1-1
1-6	Descriptions.....	1-1
1-9	Options.....	1-1
1-11	Equipment Supplied	1-2
1-13	Equipment Available.....	1-2
1-15	Warranty	1-2
Section II	Installation	
2-1	Initial Inspection.....	2-1
2-2	Mechanical Check	2-1
2-4	Performance Check.....	2-1
2-6	Claims for Damage.....	2-1
2-8	Preparation for Use.....	2-1
2-9	Power Requirements	2-1
2-11	Power Cable.....	2-1
2-15	Operating Environment	2-1
2-17	Bench Mounting	2-1
2-19	Rack Mounting	2-1
2-21	Storage and Shipment	2-1
2-22	Packaging	2-1
2-25	Original Packaging	2-2
2-27	Other Packing Material	2-2
Section III	Operation	
3-1	Introduction.....	3-1
3-4	Panel Features	3-1
3-6	Operator Checks.....	3-1

TABLE OF CONTENTS (Continued)

<u>Section</u>		<u>Page</u>
3-8	Operating Instructions.....	3-1
3-10	Operator Maintenance	3-1
3-12	Fuses	3-1
3-15	Lamp Replacement	3-1
Section IV	Performance Tests	
4-1	Introduction.....	4-1
4-4	Performance Tests	4-1
4-6	Gain Compression and Flatness	4-2
4-7	VSWR	4-5
4-8	Distortion	4-8
4-9	Noise Figure	4-9
Section V	Adjustments	
5-1	Introduction.....	5-1
5-4	Equipment Required	5-1
5-6	Model 8447A Amplifier and Adjustments	5-1
5-7	Power Supply Voltage Check and Adjustment	5-1
Section VI	Replaceable Parts	
6-1	Introduction.....	6-1
6-3	Ordering Information.....	6-1
Section VII	Manual Changes	
7-1	Manual Changes.....	7-1
7-2	Current Instruments	7-1
7-4	Older Instruments	7-1
7-6	Newer Instruments.....	7-1
Section VIII	Service	
8-1	Introduction.....	8-1
8-3	Troubleshooting.....	8-1
8-5	Schematics.....	8-1
8-7	Test Equipment and Accessories Required.....	8-1
8-9	Repair.....	8-1

TABLE OF CONTENTS (Continued)

<u>Section</u>	<u>Page</u>
8-11 Diagram Notes.....	8-1
8-13 Etched	8-1
8-15 Etched Conductor Repair.....	8-1
8-16 Component Replacement	8-1
8-17 Transistor Replacement.....	8-2
8-21 Diode Replacement	8-3
Appendix A Maintenance Allocation Charts	A-1

LIST OF TABLES

<u>Number</u>	<u>Page</u>
1-1 Specifications.....	1-1
1-2 Recommended Test Equipment and Accessories.....	1-2
2-1 Shipping Carton Test Strength	2-2
4-1 Performance Test Record	4-11
5-1 Adjustment and Check Test Record	5-3
6-1 Reference Designations and Abbreviations	6-1
6-2 Parts List Indexed by Reference Designations.....	6-2
6-3 Parts List Indexed by HP Part Number	6-5
6-4 Code List of Manufacturers	6-7
8-1 Etched Circuit Soldering Equipment.....	8-3
8-2 Schematic Notes.....	8-4
8-3 Model 8447A Component and Assembly Locations	8-5
8-4 Power Supply Voltages	8-7

LIST OF ILLUSTRATIONS

<u>Figure</u>	<u>Page</u>
1-1 HP Model 8447A Amplifier	1-0
1-2 HP Model 8447A-001 Dual Amplifier	1-0
1-3 Instrument Identification	1-2
2-1 HP Model 1051A Combining Case Instrument Installation.....	2-2
3-1 Front and Rear Panel Controls and Connectors.....	3-2
3-2 General Application of 8447A Amplifier.....	3-3
3-3 Cascade Operation of 8447A-001 Dual Amplifier	3-3
3-4 Single Amplifier Operation of 8447A-001 Dual Amplifier	3-3

LIST OF ILLUSTRATIONS (Continued)

<u>Figure</u>	<u>Page</u>
4-1 Gain, Compression, and Flatness Test Setup.....	4-2
4-2 Flatness Test Setup: 100 kHz to 1 MHz.....	4-3
4-3 Impedance Check Test Setup, 100 kHz to 500 kHz.....	4-5
4-4 Impedance Check Test Setup, 500 kHz to 100 MHz.....	4-6
4-5 Impedance Check Test Setup, 100 MHz to 400 MHz.....	4-7
4-6 Distortion Test Setup.....	4-8
4-7 Noise Figure Test Setup.....	4-9
5-1 Power Supply Voltage Adjustment Test Setup.....	5-2
6-1 Cabinet Parts.....	6-4
8-1 Examples of Diode and Transistor Marking Methods.....	8-2
8-2 Models 8447A and 8447A-001 Dual Amplifier Component and Assembly Locations.....	8-5
8-3 A1 Power Supply Component Location.....	8-8
8-4 A1 Power Supply Amplifier Schematic Diagram.....	8-9

SECTION 0

GENERAL

0-1. MAINTENANCE FORMS AND RECORDS

Department of the Army forms and procedures used for equipment maintenance will be those prescribed by TM 38-750, The Army Maintenance Management System (TAMMS).

0-2. REPORTING EQUIPMENT IMPROVEMENT RECOMMENDATIONS (EIR)

If your PATRIOT system needs improvement, let us know. Send us an EIR. You, the user, are the only one who can tell us what you do not like about your equipment. Let us know why you do not like the design. EIRs will be prepared using SF 368, Quality Deficiency Report (QDR). Mail the QDRs to Commander, U.S. Army Missile Command, ATTN: AMSMI-LC-ME-PMH, Redstone Arsenal, AL 35898-5238. A reply will be furnished to you.

0-3. ADMINISTRATIVE STORAGE

To prepare this unit for placement into and removal from administrative storage, refer to section 3, chapter 4, of AR 750-1, Maintenance Equipment and Supplies. Temporary storage should be accomplished in accordance with TB 750-25-1, section 2, Maintenance of Supplies and Equipment.

0-4. DESTRUCTION OF ARMY MATERIAL TO PREVENT ENEMY USE

For procedures for destruction of Army materiel to prevent enemy use, see section XI of TM 9-4935-393-14-1.

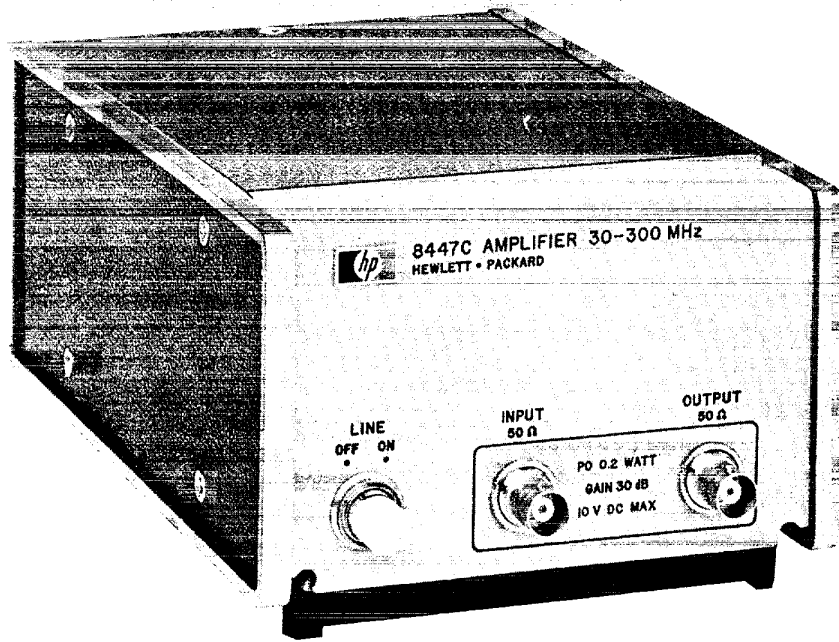

Figure 1-1. HP Model 8447a Amplifier

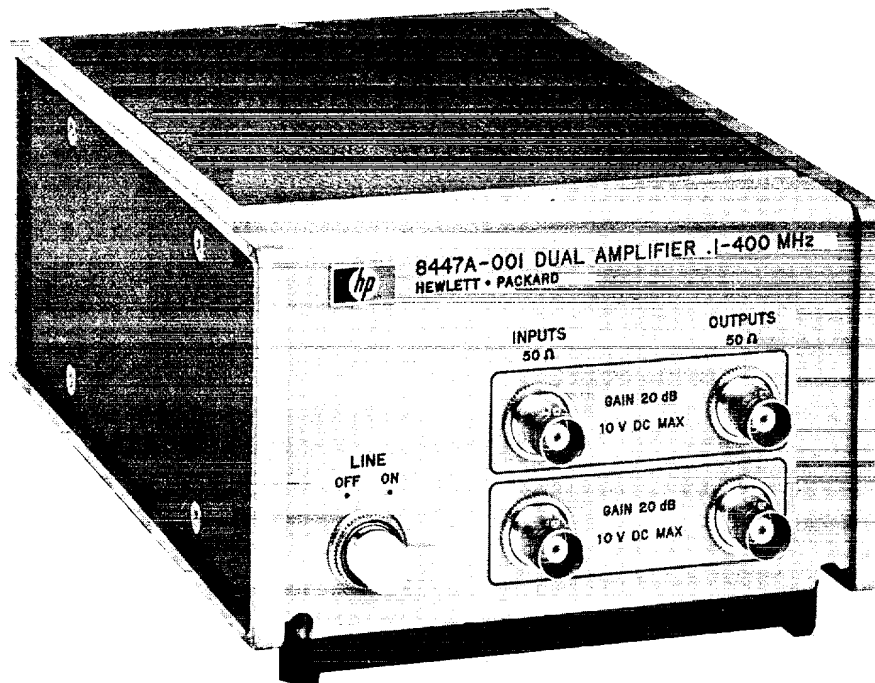

Figure 1-2. HP Model 8447A-001 Dual Amplifier

SECTION I GENERAL INFORMATION

1-1. INTRODUCTION.

1-2. This manual contains all information required to install, operate, test, adjust, and service the Hewlett-Packard Model 8447A Amplifier (see Figure 1-1). This section contains instrument identification, description, options, accessories, specifications, and other basic information.

1-3. The various sections in this manual provide information as follows:

SECTION II, INSTALLATION, provides information relative to incoming inspection, power requirements, mounting, packing and shipping, etc.

SECTION III, OPERATION, provides information relative to operating the instrument.

SECTION IV, PERFORMANCE TEST, provides information required to verify that the instrument is performing in accordance with published specifications.

SECTION V, ADJUSTMENTS, provides information required to properly adjust and align the instrument after repairs are made.

SECTION VI, PARTS LIST, provides ordering information for all replaceable parts and assemblies.

SECTION VII, MANUAL CHANGES, normally will contain no relevant information in the original issue of a manual. This section is reserved to provide back dated and up dated information in manual revision or reprints.

SECTION VIII, SERVICE, includes information necessary to efficiently service the instrument.

1-4. INSTRUMENT COVERED BY MANUAL.

1-5. Hewlett-Packard instruments carry an 8-digit serial number prefix (see Figure 1-3) on the back of the panel. When the serial number prefix on the instrument serial number plate of your instrument is the same as one of the serial prefix numbers on the inside title page of this manual, the manual applies directly to the instrument. When the instrument serial number prefix is not listed on the inside title page, manual changes sheets and manual updating information is provided. Later editions or revisions to the manual contain the required change information in Section VII.

1-6. DESCRIPTION.

1-7. HP Model 8447A Amplifier is a general purpose, low-noise, wideband amplifier (see Figure 1-1). The 8447A provides 20 dB gain to signals in 50 ohm systems from .1 to 400 MHz.

1-8. The Model 8447A amplifier can be used to make up resistive probe losses or improve sensitivity when used as a preamplifier to a spectrum analyzer or oscilloscope.

1-9. OPTIONS.

1-10. The Model 8447A -001 Dual Amplifier (see Figure 1-2) is a two-amplifier configuration which can be operated separately. Each amplifier provides 20 dB gain or the amplifiers can be cascaded by a front panel patch cable to provide a total gain of 40 dB.

Table 1-1. Specifications

Frequency Range: 0.1 to 400 MHz. Gain: 20 dB \pm 0.5 dB*. Gain Flatness: \pm 0.5 dB. Noise Figure: <5 dB, 1 to 400 MHz. Output Level: >+7 dBm at 1-dB compression point. Distortion: Harmonics at least 35 dB down at output levels up to 0 dBm. Impedance: 50 Ω n both ports, $ p $ <0.26 (VSWR <1.7). Power Requirements: 115 or 230 Vac \pm 10%, 50 to 400 Hz, 15 Watts, 27 VA max. Weight: Net, 3 lbs, 7 oz. (1.56 kg), shipping: 5 lbs, 1 oz. (2,30 kg) Dimensions: 8-1/2 inches (216 mm) by 5-1/8 inch (130 mm) by 3-3/8 inches (85.8 mm). *Measured at 10 MHz.
--

1-11. EQUIPMENT SUPPLIED.

1-12. The only equipment supplied with the Model 8447A Amplifier or the 8447A -001 Dual Amplifier is a 7.5 ft. (2290 mm) power cable.

1-13. EQUIPMENT AVAILABLE.

1-14. Table 1-2 and Table 1-3 list the test equipment and test equipment accessories necessary to test, align, and service the Model 8447A Amplifier.

1-15. WARRANTY.

1-16. Certification and warranty information for the Model 8447A Amplifier and Model 8447A-001 Dual Amplifier appears on the inside front cover of this manual.

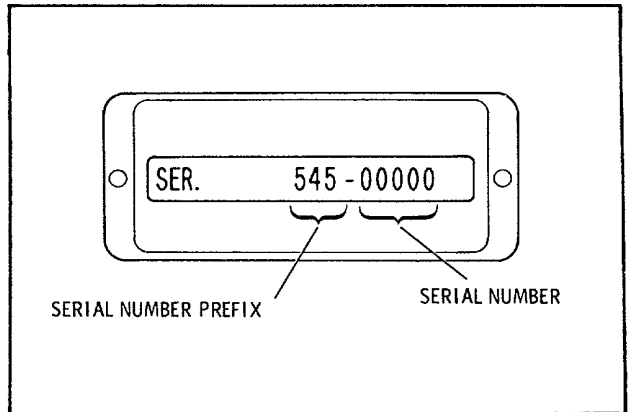

Table 1-2. Recommended Test Equipment and Accessories

Instrument Type	Critical Specifications	Recommended Model	Use (Note 1)
Signal Generator	Frequency Range: 10 MHz to 400 MHz. Output Level: -10 dBm min.	HP 608E/F	P
Test Oscillator	Frequency Range: 100 kHz to 10 MHz Output Flatness: $\pm 2\%$ Output: 30 mV	HP 651B	P
Vector Voltmeter	Frequency Range: 10 MHz To 400 MHz. Bandwidth: 1 kHz Sensitivity: 10 mV to 1 Vrms. Input Impedance: ≥ 0.1 megohm.	HP 8405A	P
AC Voltmeter	Voltage Range: 30 mV Accuracy: $\pm 1\%$	HP 400E	P, A, T
Dual Directional Coupler	Frequency Range: 100 MHz to 400 MHz. Coupling Attenuation: 20 dB nominal. Directivity: Inc port: 32 dB. Refl port: 30 dB.	HP778D	P
Vector Impedance Meter	Frequency Range: 500 kHz to 100 MHz. Accuracy: $\pm 2\%$	HP 4815A	P
Digital Voltmeter	Range: 50 V Accuracy: $\pm 1\%$	HP 3440A/3443A	A, T
Ohmmeter	Resistance Range: 1 ohm to 100 megohm. Accuracy: $\pm 10\%$	HP 412A	T
Cable Assembly	BNC Male to BNC Male 4' long.	HP 10503A	P
Cable Assembly	Type N	HP 11500A	P
Tee	BNC	UG-274B/U	P

Table 1-2. Recommended Test Equipment and Accessories (cont.)

Instrument Type	Critical Specifications	Recommended Model	Use (Note 1)
Tee(2)	50 ohms. Type N connectors.	HP 11536A	P
Adapter	BNC male to Type N Female	UG-349A/U	P
Termination	50 ohm	HP 11593A	P
Load	50 ohm	HP 908a	P
Low Pass Filter	Cutoff Frequency: 300 MHz	Telonics TLP Series	P
Spectrum Analyzer	Frequency Range: 0.5 - 400 MHz Absolute Amplitude Calibration Dynamic Range: 50 dB	HP 140A Display Section, Model 8554L Spectrum Analyzer RF Section, Model 8552A Spectrum Analyzer IF section.	
Noise Figure Meter	Frequency Range: 200 MHz Noise figure Range: 0 to 15 dB Accuracy: ± 0.5 dB	HP 342A	P
VHF Noise Source	Frequency Range: 400 MHz Excess Noise Ratio: 6.3 dB \pm 0.5 dB Noise Generator: Temperature-Limited Diode	HP 343A	P
VHF Signal Generator	Frequency Range: 600 MHz Output Level: -10 dBm	HP 612A	P
Double Balanced Mixer	Frequency Input/Output: "L" "R" ports: 600 MHz, "X" port: 200 MHz Noise Performance: 9 dB max.	HP 10514A	P
Cable Assembly (2)	BNC Male to BNC Male 9" long.	HP 10502A	P
Adapter	BNC to BNC	UG-491/U	P
Adapter	BNC Female to Type N Male	UG-201A/U	P
NOTES			
1. P = Performance Test; A = Adjustments; T = Troubleshooting			

SECTION II INSTALLATION

2-1. INITIAL INSPECTION.

2-2. Mechanical Check.

2-3. If damage to the shipping carton is evident, ask the carrier's agent to be present when the instrument is unpacked. Inspect the instrument for mechanical damage. Also check the cushioning material for signs of severe stress.

2-4. Performance Check.

2-5. The electrical performance of the Model 8447A or Model 8447A -001 should be verified upon receipt. Repeat each test on each amplifier in the Model 8447A -001 Dual Amplifier instrument. Performance checks suitable for incoming inspection are given in Sections IV, Performance Tests.

2-6. Claims for Damage.

2-7. If the instrument is mechanically damaged in transit, notify the carrier and the nearest Hewlett-Packard field office immediately. A list of field offices is contained in the back of this manual. Retain the shipping carton and padding material for the carrier's inspection. The field office will arrange for replacement or repair of your instrument without delay for claim settlements against the carrier. Before shipment, this instrument was inspected and found free of mechanical and electrical defects. If there is any deficiency, or, if electrical performance is not within specifications, notify your nearest Hewlett-Packard sales and service office.

2-8. PREPARATION FOR USE.

2-9. Power Requirements.

2-10. The Model 8447A or Model 8447A -001 operates from 115 or 230 volts ac line voltage at any line frequency between 50 and 400 Hz. A slide switch on the rear panel is set to the correct position for the line voltage available. A 0.5 ampere line fuse is required for either 115 or 230 volt operation.

2-11. Power Cable.

2-12. To protect operating personnel, the Nation Electrical Manufacturers Association (NEMA) recommends that the instrument panel and cabinet be grounded. All Hewlett-Packard instruments are equipped with a three-conductor power cable which, when plugged into the appropriate receptacle, grounds the instrument. The offset pin on the power cables three-prong connector is the ground wire.

2-13. To preserve the protection feature when operating the instrument from a 2-conductor outlet, use a three-prong to two-prong adapter and connector the green pigtail on the adapter to ground.

2-14. The power cord or power input connector meet the specifications established by the International Electrotechnical Commission (IEC).

2-15. Operating Environment.

2-16. The operating range of the Model 8447A or Model 8447 -001 is from 0° C to +55° C. The amplifier can be stored in a temperature range of -40°C to +75° C.

2-17. Bench Mounting.

2-18. The Model 8447A is equipped with plastic feet and tilt stand in place, ready for use as a bench instrument.

2-19. Rack Mounting.

2-20. The Model 8447A may be rack mounted by using an adapter frame. The adapter frame is a rack frame that accepts any combination of submodular units (see Figure 2-1). For additional information, address inquires to your nearest HP sales and service office.

2-21. STORAGE AND SHIPMENT.

2-22. Packaging.

2-23. The following paragraphs contain a general guide to repackaging of the instrument for shipment. Refer to paragraph 2-25 if the original container is to be used; refer to paragraph 2-27 if it is not.

2-24. If the instrument is to be shipped to Hewlett-Packard for service or repair, attach a tag to the instrument identifying the owner and indicating the service or repair required; include the model number and full serial number of the instrument.

2-25. Original Packaging.

2-26. If original container is to be used, proceed as follows:

- a. Place instrument in original container. If it is not available a suitable container can be purchased from your nearest HP sales and service office.
- b. Be sure the container is well sealed with strong tape or metal band.

2-27. Other Packing Material.

2-28. If original container is not used, proceed as follows:

- a. Wrap instrument in heavy paper or plastic before placing in inner container.
- b. Place packing material around all sides of the instrument and protect panel face with cardboard strips.
- c. Place instrument in a heavy carton or wooden box and seal with strong tape or metal band. See Table 2-1 for the required shipping carton test strengths.
- d. Mark shipping container: DELICATE INSTRUMENT, FRAGILE, etc.

Table 2-1. Shipping Carton Test Strength

Gross Weight (lbs)	Carton Test Strength (lbs)
up to 10	200
10 to 30	275
30 to 120	350
120 to 140	500
140 to 160	600

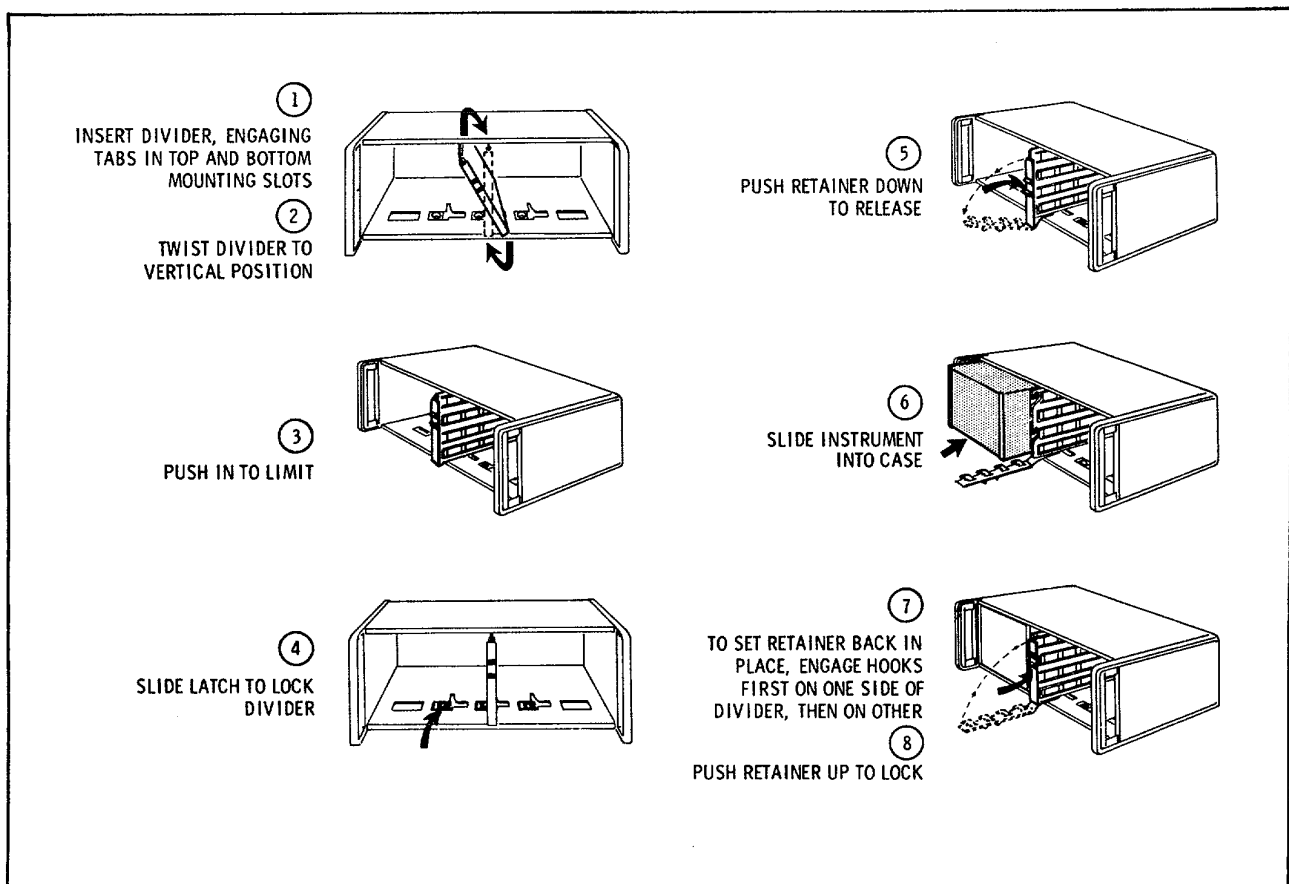

Figure 2-1. HP Model 1051A Combining Case Instrument Installation

SECTION III OPERATION

3-1. INTRODUCTION.

3-2. This section contains the basic information required to operate the Model 8447A Amplifier or the Model 8447A -001 Dual Amplifier.

3-3. The Model 8447A and the Model 8447A -001 provide 20 or 40 dB gain (cascaded amplifiers) respectively. The amplifier can be used in 50 ohm systems to increase sensitivity, make up for probe losses, and general amplification of signals from 0.1 to 400 MHz. The amplifier can also provide some amplification of signals up to 700 MHz.

3-4. PANEL FEATURES.

3-5. The Model 8447A and Model 8447-001 front and rear panel controls and connectors are explained in Figure 3-1. The descriptions are keyed to the corresponding items which are indicated on the figures. Further information regarding the various uses of the amplifiers are included in Figures 3-2, 3-3 and 3-4.

3-6. OPERATOR CHECKS.

3-7. Five steps should be taken by the operator to determine the operational condition of either the Model 8447A Amplifier or the Model 8447A-001 Dual Amplifier.

a. Turn instrument on, check to see if the front panel LINE light is on. If the light is on proceed to step c. If light is off proceed to step b.

b. If the light is off, remove the fuse from the rear panel. Check to see if the fuse is good. If the fuse is good proceed to step c. If the fuse is bad replace the fuse and turn the instrument on. If the fuse opens again, see Section VIII, Maintenance, for repair.

c. If the line fuse is good and the power switch is depressed, connect a known signal (0.1 to 400 MHz) to front panel INPUT. Monitor the OUTPUT jack to see that the Model 8447A provides approximately 20 dB gain to the input signal. If there is no gain, go to step d.

d. If the rear panel fuse is OK, turn the instrument top side down and remove the bottom cover. Check to see that the fuse on the A1 Power Supply board is good. If the fuse is bad, replace the fuse and turn the instrument back on. If the fuse blows again, see Section VIII, Maintenance, for repair.

e. If the Model 8447A provides the proper gain and the front panel light is out, replace the lamp (see paragraph 3-10, Operator Maintenance).

NOTE

Be sure to provide 50Ω source and load impedances.

3-8. OPERATING INSTRUCTIONS.

3-9. Figure 3-2 thru 3-4 contain general application information for the Model 8447A and the Model 8447 -001 Dual Amplifiers.

3-10. OPERATOR MAINTENANCE.

3-11. Operator maintenance is limited to replacement of the front panel LINE switch light, the A1 power supply fuse, and the rear panel fuse. For any internal maintenance on the amplifiers, see Section VII, Maintenance.

3-12. FUSES.

3-13. To replace the rear panel fuse (F1), remove the rear panel fuse knob and replace the fuse with 0.5 amp 250 V fuse.

3-14. To replace the A1 Power Supply (A1F1) fuse, turn the instrument on its top. Lift tilt stand and remove the bottom cover. Replace the fuse on the A1 Power Supply board with 0.5 amp 250 V fuse.

3-15. LAMP REPLACEMENT.

3-16. To replace the front panel line switch lamp (DS1), proceed as follows:

a. Disconnect cord from rear panel receptacle.

b. Pull the white cover portion of this switch from the instrument and then remove the lamp from inside the cover.

c. Replace old lamp with a new lamp (see Section VI for part number of DS1).

d. Place white cover into switch receptacle.

e. Align tab on white cover with socket and push in.

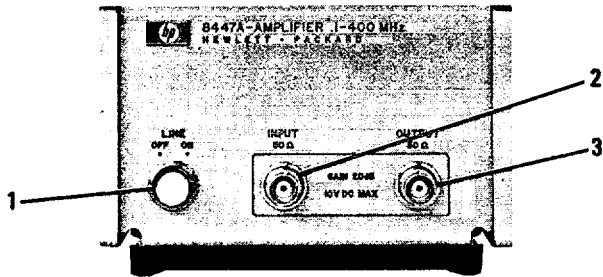

1. LINE ON/OFF: Instrument power on/off switch.
2. INPUT 50Ω : connects input signal to amplifier.

CAUTION

Do not apply more than 10 volts dc to the input. Maximum power that can be applied to the input from a 50 ohm source is 1 Watt. When connecting the amplifier to a low impedance source, a limiting resistor must be placed in series with the input port to limit the peak current to a maximum of 150 mA. To compute limiting resistor, assume that the input impedance can be as low as 2Ω under overload conditions.

3. OUTPUT 50Ω: Connects amplifier output to load.

CAUTION

Do not apply more than 30 volts dc to output.

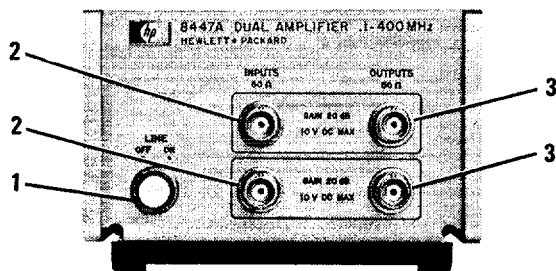

4. **SELECTOR:** Selects 115 volts ac or 230 volts ac primary power.
5. Fuseholder: Contains 0.5 ampere fuse for 115 or 230 volt operation.
6. AC Power Connection: Connects line power to the instrument.

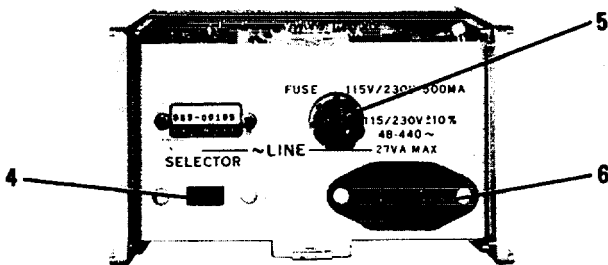

Figure 3-1. Front and Rear Panel controls and connectors

Model 8447A

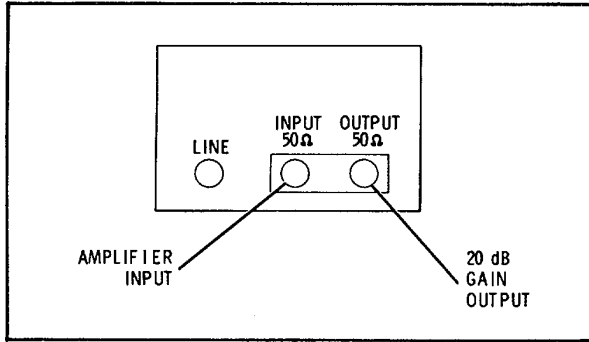

Figure 3-2. General Application of 8447A Amplifier

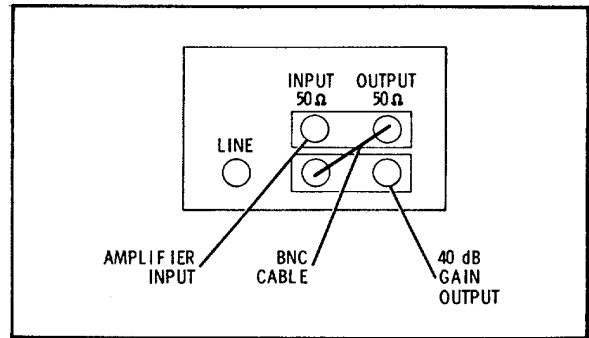

Figure 3-3. Cascade Operation of 8447A-001 Dual Amplifier

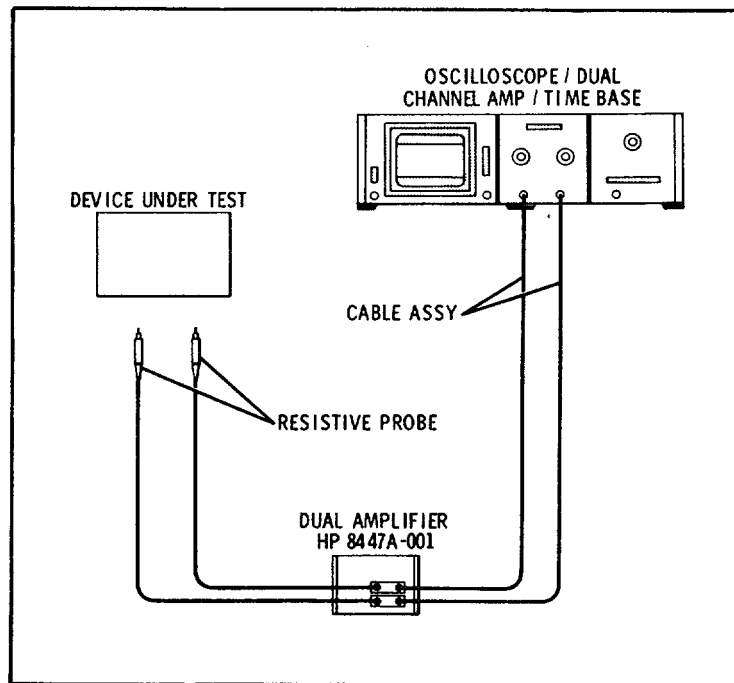

Figure 3-4. Single Amplifier Operation of 8447A-001 Dual Amplifier

SECTION IV**PERFORMANCE TESTS****4-1. INTRODUCTION.**

4-2. Perform tests with the test equipment called for, or with its equivalent. Specifications of test equipment and accessories required to performance-test the amplifier are given in Table 1-1; a complete list of accessories and test equipment for alignment and adjustment, are given in Table 1-2.

4-3. Procedures for verifying that the instrument meets specifications are given in Paragraphs 4-6 through 4-9 and a test card in Table 4-1 contains data spaces for recording test results.

4-4. PERFORMANCE TESTS.

4-5. The performance tests given in this manual are suitable for incoming inspection, troubleshooting or preventive maintenance. The tests are designed to verify published instrument specifications. Record the tests data on the test card (Table 4-1) at the end of this section.

PERFORMANCE TESTS (contd)

4-6. Gain Compression, & Flatness.

SPECIFICATIONS:

Gain: 20 dB ± 0.5 dB at 10 MHz.
 Output Level (Compression): >±7 dBm at 1 dB compression point
 Flatness: ±0.5 dB.

DESCRIPTION:

Using a two-channel tuned voltmeter, the input and output levels of the Model 8447A Amplifier are compared to determine gain, gain compression, and flatness (frequency response).

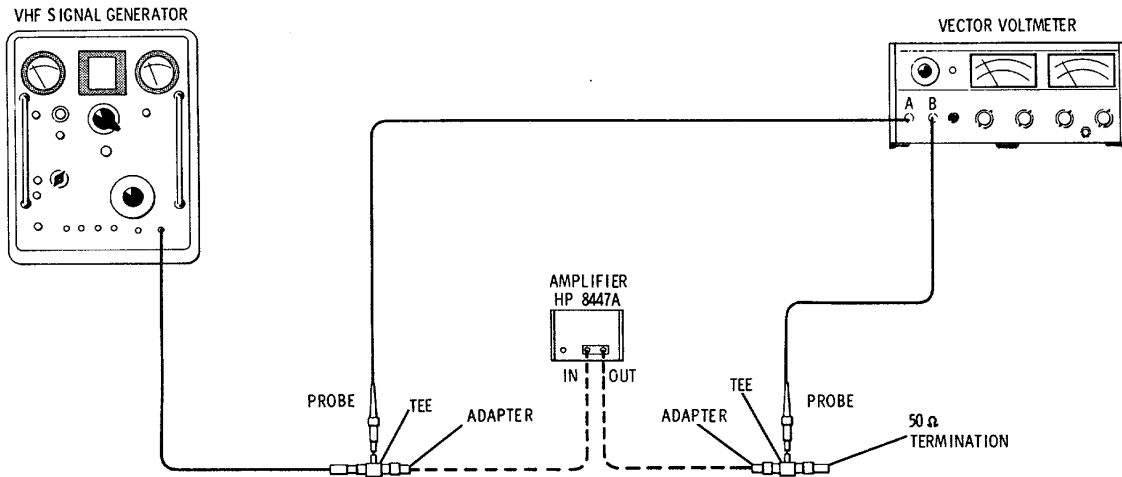

Figure 4-1. Gain, Compression and Flatness Test Setup

EQUIPMENT:

Signal Generator	HP 608E/F
Test Oscillator	HP 651B
Vector Voltmeter	HP 8405A
AC Voltmeter	HP 400E
BNC Cable (2)	HP 10503A
50W Feedthrough Tee (2)	HP 11536A
50W Termination	HP 908A
50W Termination	HP 11593A
Type N Cable	HP 11500A
BNC Tee	UG-274B/U

1. Connect the test setup as shown in Figure 4-1. Make the following control settings:

608E/F

MODULATION	CW
ATTENUATION	See Procedure
FREQUENCY RANGE.....	A
MEGACYCLES	10
AMPL TRIMMER	Press and peak meter reading

PERFORMANCE TESTS (contd)

4-6. Gain Compression & Flatness (contd).

8405A

FREQUENCY RANGE-MHz..... 10-20
 AMPLITUDE RANGE-DB -40
 CHANNEL..... A

2. Connect the output of the Channel A probe tee directly to the Channel B probe tee bypassing the Model 8447A Amplifier. Adjust the 608E/F signal level for a 0 reading on the dB scale of the Model 8405A meter (-40 dBm).
3. Switch the Model 8405A to Channel B and note the difference from CHANNEL A. This error, if any, must be taken into consideration for all subsequent readings of Channel A versus Channel B.
 Error: _____
4. Connect the Model 8447A between the Channel A probe tee and the Channel B probe tee. Set the Model 8405A to CHANNEL A and readjust, if necessary, the 608E/F level for 0 on the 8405A dB scale. Switch to CHANNEL B and record the difference from Channel A.
 Gain: +19.5 _____ +20.5 dB
5. To check for gain compression increase the Model 608E/F signal level to +7 dBm on Channel B. The gain (difference between Channel A and Channel B) should be within 1 dB of the gain as measured in step 4.
 Compression (gain change from step 4): _____ 1 dB
6. To check flatness, set the signal level at Channel A to -40 dBm. Note the level difference between Channel A and Channel B as the generator frequency is tuned from 10 MHz to 400 MHz. Keep the input level to the amplifier (CHANNEL A) constant and note the variation in Channel B. Channel B should change <1 dB (± 0.5 dB).
 Flatness: _____ 1 dB
7. Substitute the Model 651B Test Oscillator in place of the Model 608E/F and repeat step 6 to check 1 MHz to 10 MHz.
 Flatness (Total variation step 6 plus step 7): _____ 1 dB
8. Note the Channel B reading with respect to 0 on the dB scale at 1 MHz.
 \pm dB from 0: _____

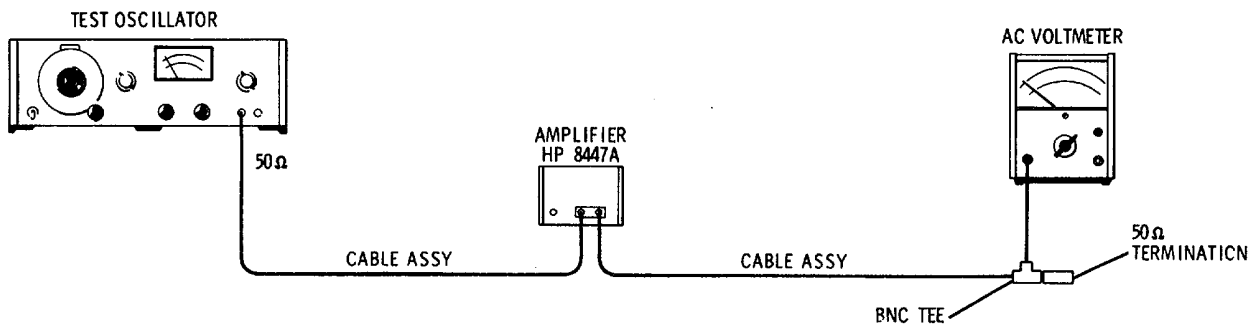

Figure 4-2. Flatness Test Setup: 100 kHz to 1 MHz

PERFORMANCE TESTS (contd)

4-6. Gain Compression & Flatness (contd).

9. Connect the test setup as shown in Figure 4-2. Set the Model 400E to the -20 dB range and adjust the Model 651B output at 1 MHz to obtain the same relative reading from 0 dB on the Model 400E as in measured in step 8. Note the level variation on the Model 400E as the Model 651B frequency is tuned from 1 MHz to 100 kHz.

Flatness (Total variation from steps 6, 7, and 9): _____ 1 dB

NOTE

The Model 651B output may not be flat. To check its flatness from 100 kHz to 1 MHz, connect the 50 Ω output directly to a 50 Ω loaded Model 400E and note any change with frequency in amplitude from 100 kHz to 1 MHz. This error must be considered when performing step 9.

PERFORMANCE TESTS (contd)

4-7. VSWR.

SPECIFICATION:

Impedance: 50Ω both parts, $|p| < 0.26$ (VSWR < 1.7)

DESCRIPTION:

The amplifier input and output impedance is checked over three frequency ranges. Over the 100 kHz to 500 kHz range, an oscillator is terminated in a known impedance and calibrated. The voltage across the known impedance is then compared with the voltage across the amplifier input and then the output terminals. A vector impedance meter is used to check the 500 kHz to 100 MHz range. From 100 MHz to 400 MHz, the input and output impedance is checked by comparing the reflected power to the incident power applied from a signal source.

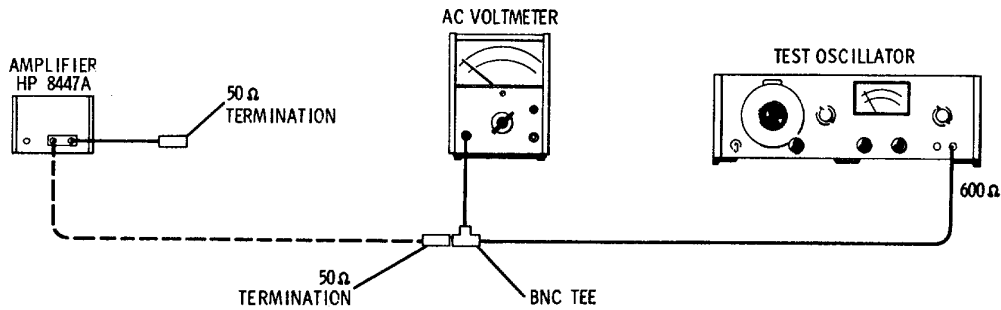

Figure 4-3. Impedance Check Test Setup, 100 kHz to 500 kHz

EQUIPMENT:

RF Vector Impedance	HP 4815A
Test Oscillator	HP 651B
AC Voltmeter	HP 400E
Vector Voltmeter	HP 8405A
Signal Generator	HP 608E/F
Dual Directional Coupler	HP 778D
50 - Ohm Tee (2)	HP 11536A
50 - Ohm Load (3)	HP 908A
Type N Cable	HP 11500A
50 - Ohm Termination	HP 11593A
Cable Assembly (2)	HP 10503A
BNC Tee	UG-274B/U
Adapter BNC Male to Type N Female (2)	UG-349A/U

1. Connect the equipment as shown in Figure 4-3. Make the following control settings:

400E:

RANGE..... 30 mV

PERFORMANCE TESTS (contd)

4-7. VSWR (contd)

651B:

FREQUENCY	1
RANGE.....	100K
OUTPUT ATTENUATOR.....	0.3V

2. Set the oscillator for 15 mV as indicated on the Model 400E voltmeter.
3. Replace the 50-ohm termination with a cable assembly and connect the cable to the amplifier INPUT.
4. Measure the voltage across the amplifier input. For a VSWR of less than 1.7, the voltmeter should indicate between 9.1 and 24.2 mV.

Voltmeter reading: 9.1 _____ 24.2 mV

5. Change oscillator frequency in steps from 100 kHz to 500 kHz. Repeat steps 2 through 4 at each frequency step.

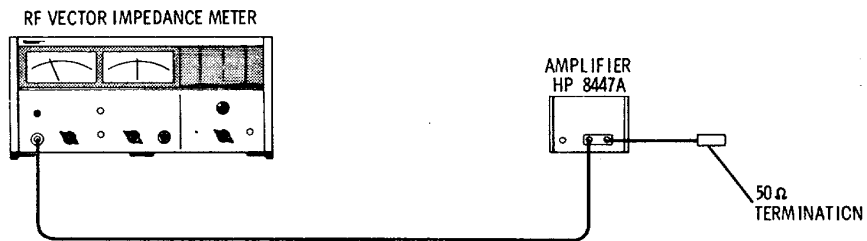

Figure 4-4. Impedance Check Test Setup, 500 kHz to 100 MHz

6. Connect the equipment as shown in Figure 4-4. Make the following controls settings:

4815A:

MAGNITUDE RANGE (Ω 1).....	100
RANGE MHz.....	0.5-1.5

7. Slowly tune the impedance meter through each frequency band. Observe OHM meter for indicated impedance. For a VSWR of less than 1.7, the meter should indicate between 29.4 and 85.0 ohms.

Impedance: 29.4 _____ 85.0 ohms

PERFORMANCE TESTS (cont'd)

4-7. VSWR (contd).

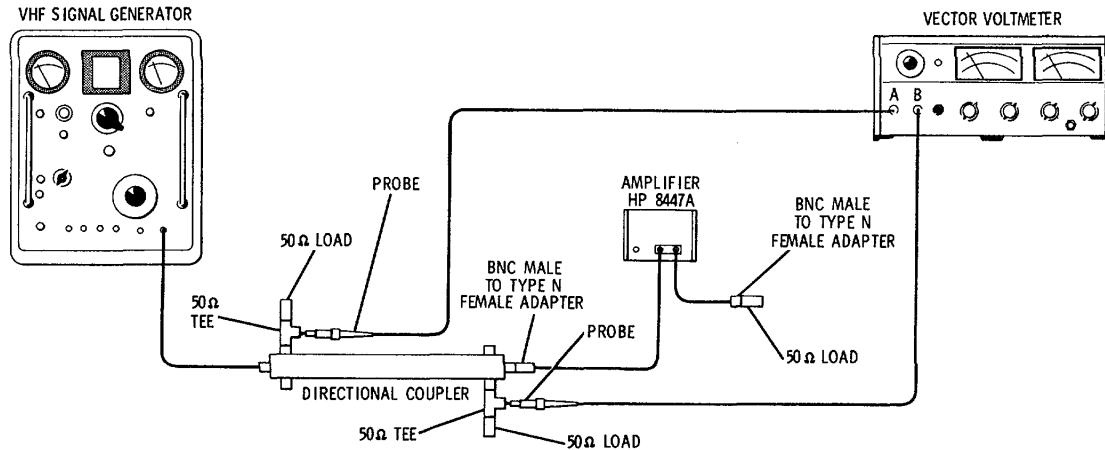

Figure 4-5. Impedance Check Test Setup, 100 MHz to 400 MHz

8. Connect the equipment as shown in Figure 4-5. Make the following controls settings:

8405A:

FREQUENCY RANGE-MHz	100-200
AMPLITUDE RANGE-DB	-50
CHANNEL	A
PHASE RANGE	±180

608E/F:

MODULATION	CW
ATTENUATION	-30 dBm
FREQUENCY RANGE	D
MEGACYCLES	100
AMPL TRIMMER.....	Press and peak meter reading

9. Adjust the 608E/F output so that the Model 8405A reads 0 on the dB scale. Switch to CHANNEL B and note the meter reading. Channel B should be ≥ 11.6 dB below the Channel A level. This 11.6 dB return loss limit corresponds to a 1.7 VSWR.

Return Loss: 11.6 dB _____

10. Repeat step 11 at other frequencies from 100 MHz to 400 MHz by changing the Model 608E/F frequency. Make certain that the Model 8405A FREQ RANGE- MHz control setting correspond to the measurement frequency.

Return Loss: 11.6 dB _____

11. To measure the output impedance, repeat steps 1 through 11. Make sure that the 50-ohm termination or load is placed on the amplifier INPUT terminal.

Voltmeter reading:	100 kHz to 500 kHz	9.1 _____	24.2 mV
Impedance:	500 kHz to 100 MHz	29.4 _____	85 ohms
Return Loss:	100 MHz to 400 MHz	11.6 dB _____	

PERFORMANCE TESTS (contd)

4-8. Distortion.

SPECIFICATION:

Harmonics at least 35 dB down at output levels up to 0 dBm.

DESCRIPTION:

A spectrum analyzer is used to observe the relative amplitude between the fundamental and second harmonic of an undistorted signal applied to the amplifier input. The input signal level is adjust to give a 0 dBm signal at the amplifier output.

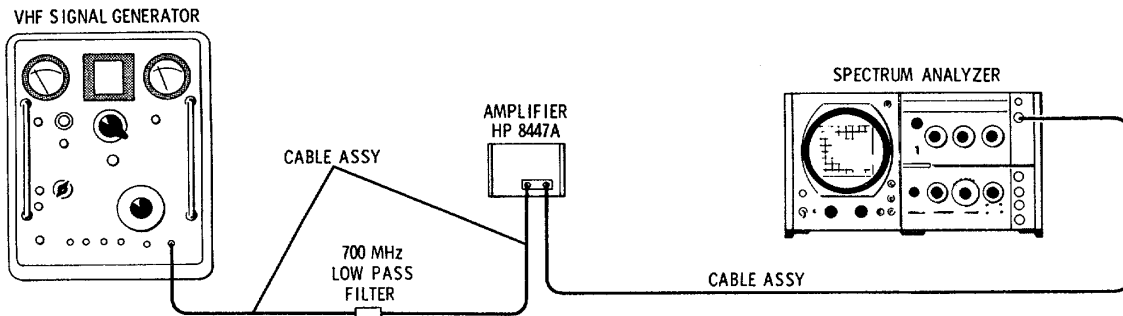

Figure 4-6. Distortion Test Setup

EQUIPMENT:

Signal Generator	HP 608E/F
Low Pass Filter 300 MHz	Telonics TLP Series
Cable Assembly (3)	HP 10503A
Display Section	HP 140S
Spectrum Analyzer RF Section.....	HP 8554L
Spectrum Analyzer IF Section	HP 8552A

1. Connect the test setup as shown in Figure 4-6. Make the following control settings:

8554L/8552A	
FREQUENCY.....	250 MHz
BANDWIDTH	100 kHz
SCAN WIDTH	PER DIVISION
SCAN WIDTH PER DIVISION.....	2 MHz
INPUT ATTENUATION	20 dB
SCAN TIME PER DIVISION.....	20 MILLISECONDS
LOG/LINEAR.....	LOG
LOG REF LEVEL	0 dBm
LOG REF LEVEL Vernier	0 dB
VIDEO FILTER.....	10 kHz
SCAN MODE	INT
SCAN TRIGGER.....	LINE

2. Adjust the signal generator input amplitude at 250 MHz to obtain a 0 dBm output level as indicated on the spectrum analyzer CRT display.

3. Tune the analyzer control to 500 MHz and note the level of the second harmonic. The second harmonic should be at least 35 dB below the fundamental signal level.

-35 dB _____

Model 8447A

PERFORMANCE TESTS (contd)

4-9. Noise Figure.

SPECIFICATIONS:

<5 dB, 1 - 400 MHz

DESCRIPTION:

Noise figure is checked by periodic insertion of a known amount of excess noise at the input of the amplifier under test, creating a pulse train of two noise power levels. The HP Model 342A detects the power and meters the noise figure directly in dB.

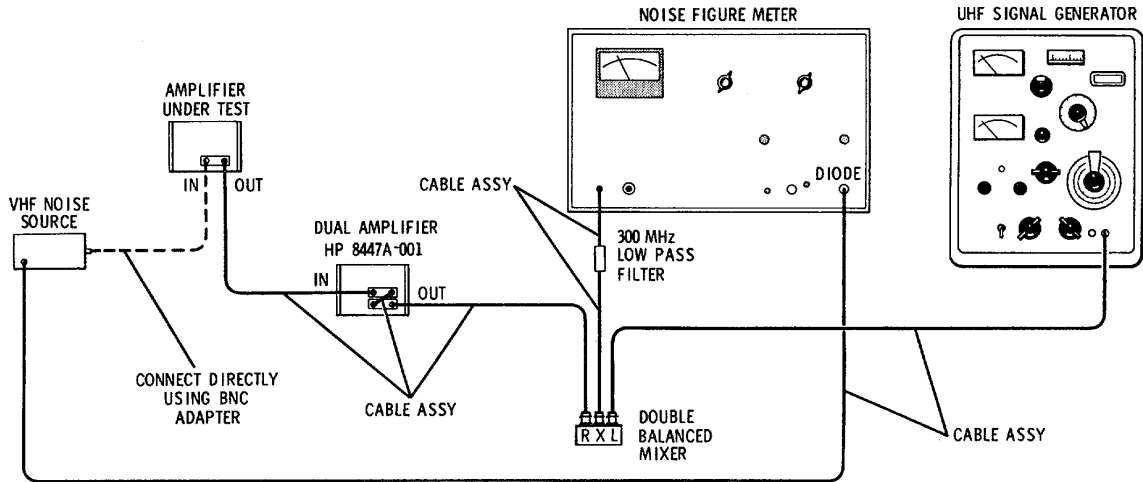

Figure 4-7. Noise Figure Test Setup

EQUIPMENT:

Noise Figure Meter	HP 342A
VHF Noise Source	HP 343A
UHF Signal Generator	HP 612A
VHF Signal Generator	HP 608E
Adapter	UG-201A/U
Low Pass Filter	Telonics TLP Series
Dual Amplifier	8447A-001
Double Balanced Mixer	HP 10514A
Cable Assembly (3)	HP 10503A
Cable Assembly (2)	HP 10502A
BNC-BNC Adapter	UG-491/U

1. Connect the test setup as shown in Figure 4-7. Make the following control settings:

612A:

OUTPUT LEVEL	-10 dBm
MEGACYCLES	600
Modulation	CW

342A:

INPUT (MC)	200
NOISE SOURCE	DIODE

PERFORMANCE TESTS (contd)**4-9. Noise Figure (contd).**

2. Set the 342A METER FUNCTION to CURRENT and adjust the CURRENT control for the diode current as specified on the Model 343A VHF Noise Source.
3. Set the Model 342A METER FUNCTION to ZERO and INF CALIBRATION and adjust for proper meter readings as necessary.
4. Set METER FUNCTION to NOISE FIGURE and read the noise figure of the Model 8447A under test. Since the signal generator is set at 600 MHz, the noise figure of the device is being measured at 400 MHz. The noise figure should be <5 dB

Noise Figure: _____<5dB

5. Substitute the Model 612A with the Model 608E and repeat steps 2, 3, and 4 to check noise figure at 280, 200, and 100 MHz by setting the signal generator to 480, 400, and 300 MHz respectively.

Noise Figure: _____<5dB

Table 4-1. Performance Test Record

Hewlett-Packard Model 8447A Amplifier		Test Performed by _____			
Serial No. _____		Date _____			
Para. No.	Test Description	Measurement Unit	Min	Actual	Max
4-6	Gain Compression, & Flatness				
3	Error	dB		_____	
4	Gain	dB	19.5	_____	20.5
5	Compression (gain change from step 4)	dB		_____	1
6	Flatness (1 MHz to 10 MHz)	dB		_____	1
7	Flatness (1 MHz to 10 MHz) (total variation step 6 plus step 7)	dB		_____	1
8	Channel B reading \pm dB from 0	dB		_____	
9	Flatness (100 kHz to 1 MHz) (total variation steps 6,7 and 9)	dB		_____	1
4-7	VSWR				
4	Voltmeter Reading	mV	+9.1	_____	+24.2
7	Impedance	ohms	24.9	_____	85.0
9	Return Loss	dB	11.6	_____	
10	Return Loss	dB	11.6	_____	
11	Voltmeter Reading	mV	+9.1	_____	+24.2
11	Impedance	ohms	29.4	_____	85.0
11	Return Loss	dB	11.6	_____	
4-8	Distortion				
3	Distortion	dB	-35	_____	
4-9	Noise Figure				
4	Noise Figure (400 MHz)	dB		_____	5
5	Noise Figure (280 MHz)	dB		_____	5
5	Noise Figure (200 MHz)	dB		_____	5
5	Noise Figure (100 MHz)	dB		_____	5

Model 8447A

SECTION V

ADJUSTMENTS

5-1. INTRODUCTION.

5-2. This section describes adjustments required to return the Model 8447A Amplifier (or Model 8447A-001 Dual Amplifier) to peak operating condition when repairs are required. Included in this section are test setups, checks and adjustment procedures. A test card for recording data is included at the back of this section. Adjustment location photographs are contained in foldouts in Section VIII of this manual.

5-3. Record data, taken during adjustments, in the spaces provided or on the data test card at the end of this section. Comparison of initial data with data taken during periodic calibration assists in preventive maintenance and troubleshooting.

5-4. EQUIPMENT REQUIRED.

5-5. Table 1-2 contains a tabular list of test equipment and test accessories called out in the adjustment procedures. In addition, the tables contains the required minimum specifications and a suggested manufacturers model number.

5-6. Model 8447A Amplifier and Adjustments.

5-7. Only one adjustment/check step is required on the Model 8447A. This is the Power Supply Check and Adjustment.

Model 8447A

ADJUSTMENT PROCEDURES

5-8. Power Supply Voltage Check and Adjustment.

DESCRIPTION:

To make sure that the RF amplifier gives the proper gain, the power supply is adjusted to +28 volt ± 0.1 volt.

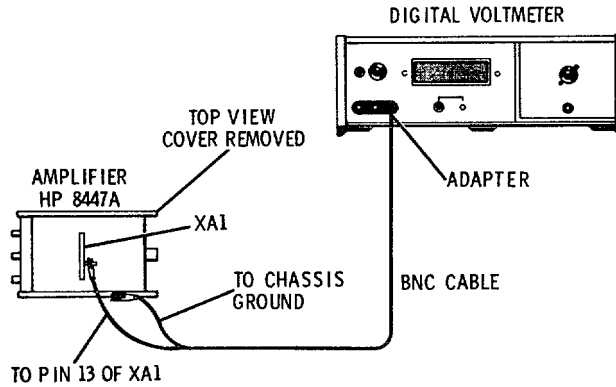

Figure 5-1. Power Supply Voltage Adjustment Test Setup

EQUIPMENT:

Digital Voltmeter..... HP 3440A/3443A

1. Connect the setup in Figure 4-1. Make the following control settings.

HP 3440A/3443A

RANGE AUTO

2. Adjust A1R9 VOLT ADJ for a digital voltmeter reading of +28 V ± 0.1 Vdc.

DVM: 27.9 _____ 28.1V

3. Remove the digital voltmeter from the Model 8447A. Connect the HP Model 400E to Pin 14 of XA1. The ripple voltage should be <0.35 mVrms.

_____ 0.35mVrms

Table 5-1. Adjustment and Check Test Record

Hewlett-Packard Model 8447A Amplifier		Test Performed by _____			
Serial No. _____		Date _____			
Para. No.	Test Description	Measurement Unit	Min	Actual	Max
5-8	Power Supply Check & Adjustment				
2	+28 volts ± 0.1 volt	Vdc	+27.9 _____		+28.1
3	Ripple Voltage <0.35mVrms	mVrms		_____	0.35

5-3/(5-4 blank)

SECTION VI

REPLACEABLE PARTS

6-1. INTRODUCTION.

6-2. This section contains information for ordering replacement parts. Table 6-2 lists parts in alphanumerical order of their reference designators and indicates the description and HP stock number of each part, together with any applicable notes. Miscellaneous parts are listed at the end of Table 6-2. Table 6-3 lists parts in alphanumerical order of their HP stock number and provides the following information on each part:

- a. Description.
- b. Manufacturer of the part in a five-digit code; see list of manufacturers in Table 6-4.
- c. Manufacturer's part number.
- d. Total quantity used (TQ column).

6-3. ORDERING INFORMATION.

6-4. To obtain replacement parts, address order or inquiry to your local Hewlett-Packard Field Office (see list at rear of this manual for address). Identify parts by their Hewlett-Packard stock numbers.

6-5. To obtain a part that is not listed, include:

- a. Instrument model number.
- b. Instrument serial number.
- c. Description of the part.
- d. Function and location of the part.

Table 6-1. Reference Designations and Abbreviations

REFERENCE DESIGNATORS					
<p>A = assembly B = motor BT = battery C = capacitor CP = coupler CR = diode DL = delay line DS = device signaling (lamp) E = misc electronic part</p>	<p>F = fuse FL = Filter J = jack K = relay L = inductor LS = loud speaker M = meter MK = microphone MP = mechanical part</p>	<p>P = plug Q = transistor R = resistor RT = thermistor S = switch T = transformer TB = terminal board TP = test point U = integrated circuit</p>	<p>V = vacuum tube, neon bulb, photocell, etc. VR = voltage regulator W = cable X = socket Y = crystal Z = tuned cavity, network</p>		
ABBREVIATIONS					
<p>A = amperes AFC = automatic frequency control AMPL = amplifier BFO = beat frequency oscillator BE CU = beryllium copper BH = binder head BP = bandpass BRS = brass BWO = backward wave oscillator CCW = counterclockwise CER = ceramic CMO = cabinet mount only COEF = coefficient COM = common COMP = composition COMPL = complete CONN = connector CP = cadmium plate CRT = cathode-ray tube CW = clockwise DEPC = deposited carbon DR = drive ELECT = electrolytic ENCAP = encapsulated EXT = external F = farads FH = flat head FIL H = Fillister head FXD = fixed G = giga (10⁹) GE = germanium GL = glass GRD = ground(ed)</p>	<p>H = henries HDW = hardware HEX = hexagonal HG = mercury HR = hour(s) Hz = Hertz IF = intermediate freq IMPG = impregnated INCD = incandescent INCL = include(s) INS = insulation(ed) INT = internal K = kilo = 1000 LH = left hand LIN = linear taper LK WASH = lock washer LOG = logarithmic taper LPF = low pass filter M = milli = 10⁻³ MEG = meg = 10⁶ MET FLM = metal film MET OX = metallic oxide MFR = manufacturer MHz = mega Hertz MINAT = miniature MOM = momentary MOS = metalized substrate MTG = mounting MY = "mylar" N = nano (10⁻⁹) N/C = normally closed NE = neon NI PL = nickel plate</p>	<p>N/O = normally open NOM = nominal NPO = negative positive zero (zero temperature coefficient) NPN = negative-positive-negative NRFR = not recommended for field replacement NSR = not separately replaceable OBD = order by description OH = oval head OX = oxide P = peak PC = printed circuit PF = picofarads = 10⁻¹² farads PH BRZ = phosphor bronze PHL = Phillips PIV = peak inverse voltage PNP = positive-negative-positive P/O = part of POLY = polystyrene PORC = porcelain POS = position(s) POT = potentiometer PP = peak-to-peak PT = point PWV = peak working voltage RECT = rectifier RF = radio frequency RH = round head or right hand</p>	<p>RMO = rack mount only RMS = root-mean square RWV = reverse working voltage S-B = slow-blow SCR = screw SE = selenium SECT = section(s) SEMICON = semiconductor SI = silicon SIL = silver SL = slide SPG = spring SPL = special SST = Stainless steel SR = split ring STL = steel TA = tantalum TD = time delay TGL = toggle THD = thread TI = titanium TOL = tolerance TRIM = trimmer TWT = traveling wave tube μ = micro = 10⁻⁶ VAR = variable VDCW = dc working volts W/ = with W = watts WIV = working inverse voltage WW = wirewound W/O = without</p>		

Table 6-2. Parts List Indexed by Reference Designation

Reference Designation	Part No.	Description #	Note
A1	J8447-60001	BOARD ASSY:POWER SUPPLY	
	08447-20001	BOARD:BLANK PC	
A1C1	J150-0024	C:FXD CER 0.02 UF +80-20% 60OVDCW	
A1C2	0180-0228	C:FXD ELECT 22 UF 10% 15VDCW	
A1C3	0160-0162	C:FXD MY 0.022 UF 10% 20OVDCW	
A1C4	0180-0116	C: FXD ELECT 6.8 UF 10% 35VDCW	
A1C5	0180-1819	C:FXD ELECT 100 UF +75-10% 50VDCW	
A1CR1	1901-0159	DIDDE:SILICON 0.75A 400PIV	
A1CR2	1901-0159	DIODE:SILICON 0.75A 400PIV	
A1CR3	1901-0159	DIODE:SILICON 0.75A 400PIV	
A1CR4	1901-0159	DIODE:SILICON 0.75A 400PIV	
A1 CR5	1902-3036	DIODE BREAKDOWN:SILICON 3.16V	
A1CR6	1902-0761	DIODE:BREAKDOWN 5.9 TO 6.5V	
A1CR7	1901-0025	DIODE:SILICON 100MA/1V	
A1CR8	1902-3290	DIODE BREAKDOWN:SILICON 31.6V 5%	
A1CR9	1884-0012	RECTIFIER: SILICON CONTROLLED 2N3528	
A1CR10	1901-0025	DIODE:SILICON 100MA/1V	
A1F1	2110-0012	FUSE:CARTRIDGE 0.5A(230V OPERATION)	
	2110-0269	CLIP:FUSE 0.250" DIA	
A101	1853-0012	Q:SI PNP	
A102	1854-0022	Q:SI NPN	
A103	1854-0071	Q:SI NPN(SELECTED FROM 2N3704)	
A104	1854-0071	Q:SI NPN(SELECTED FROM 2N3704)	
A105	1854-0071	Q:SI NPN(SELECTED FROM 2N3704)	
A1R1	0757-0637	R:FXD MET FLM 8.25K OHM 1% 1/2W	
A1R2	0757-0278	R:FXD MET FLM 1.78K OHM 1% 1/8W	
A1R3	0757-0839	R:FXD MET FLM 10K OHM 1% 1/2W	
A1R4	0811-1668	R:FXD WW 1.5 OHM 5% 2W	
A1R5	0698-3101	R:FXD MET FLM 2.87K OHM 1% 1/2W	
A1R6	0698-0083	R:FXD MET FLM 1:96K OHM 1% 1/8W	
A1R7	0698-3440	R:FXD MET FLM 196 OHM 1% 1/8W	
A1R8	0757-0416	R:FXD MET FLM 511 OHM 1% 1/8W	
A1R9	2100-1758	R:VAR WW 1K OHM 5% TYPE V 1W	
A1R10	0757-0290	R:FXD MET FLM 6.19K OHM 1% 1/8W FACTORY SELECTED PART	
A1R11	0757-1094	R:FXD MET FLM 1.47K OHM 1% 1/8W	
A1R12	0598-3442	R:FXD MET FLW 237 OHM 1% 1/8W	
C1	0180-2272	C:FXD ELECT 850 UF +50-10% 75VDCW	
	1210-0013	BRACKET:MOUNTING FOR 1-3/8" OD	
C2	0160-2437	C:FXD CER 5000 PF +80-20% 200VDCW	
D51	2140-0244	LAMP:GLOW MINIATURE 95V	
F1	2110-0012	FUSE:CARTRIDGE 0.5A(230V OPERATION)	
J1	1251-2357	CONNECTOR:AC POWER 3 MALE CONTACTS	
J2		PART OF W2	
J3		PART OF W2	

See introduction to this section for ordering information

Model 8447A

Table 6-2. Parts List Indexed by Reference Designation (contd)

Reference Designation	Part No.	Description #	Note
J4, J5 J6, J7 J8, J9		PART OF W3 PART OF W4 PART OF W5	
Q1	1854-0063 1200-0041 1200-0043	Q:SI NPN SOCKET:TRANSISTOR INSULATOR:TRANSISTOR MOUNTING	
R1	0683-2735	R:FXD COMP 27K OHM 5% 1/4W	
S1	3101-1244	SWITCH:PUSHBUTTON SPDT-DB	
S2	3101-1234	SWITCH:SLIDE DPDT	
T1	9100-2894	TRANSFORMER:POWER	
O1	1820-0169	INTEGRATED CIRCUIT : PRE-AMP 0.1-400MHZ	
U2	1820-0169	INTEGRATED CIRCUIT : PRE-AMP 0.-400MHZ (DPTION 001)	
W1	3120-1348	CABLE ASSY:POWER, DETACHABLE	
W2	08447-6003	CABLE ASSY:INPUT	
W3	0447-6003	CABLE ASSY:OUTPUT	
W4	08447-60003	CABLE ASSY	
W5	08447-60003	CABLE ASSY	
XA1	1251-3135	CONNECTOR:BODY 15 PIN	
XA1	1400-0084	FUSEHOLDER:EXTRACTOR POST TYPE	
	0900-0016	MISCELLANEOUS " 0" RING:11/16"	
	2190-0037	WASHER:LOCK SST FOR 1/2 THREAD	
	2950-0038	NUT:HEX SST 1/2-24 X 11/16	

See introduction to this section for ordering information

Table 6-2. Parts List Indexed by Reference Designation (contd)

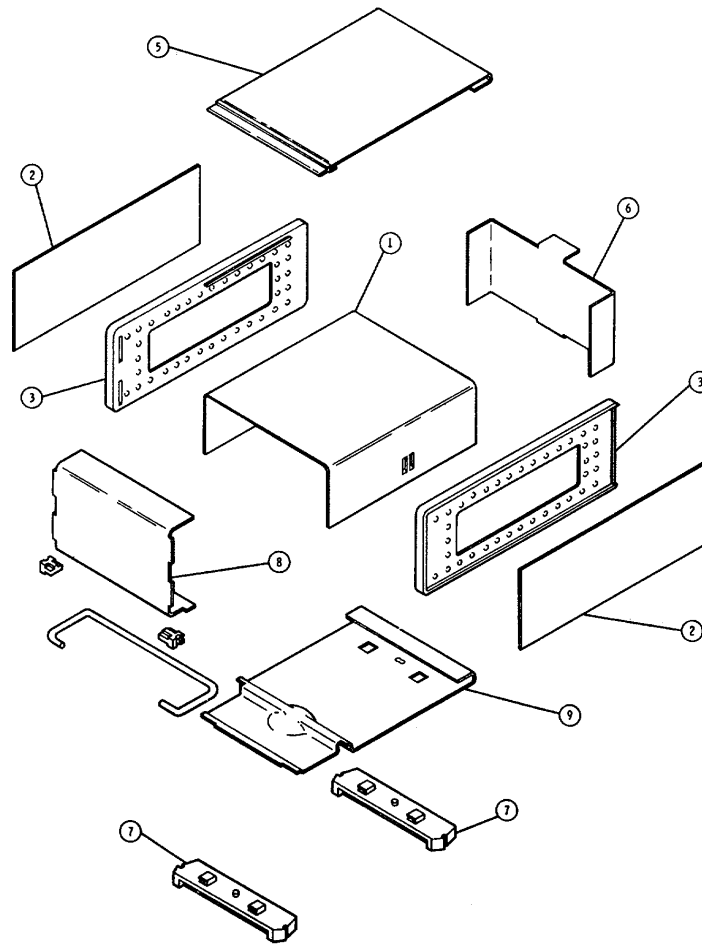

Figure 6-1. Cabinet Parts

Reference Designation	Part No.	Description
1	08447-00003	DECK:MAIN
2	5000-7891	SIDE COVER:3 X 8
3	5060-0247	FRAME ASSGND
4		NOT ASSY
5	5060-0708	TOP COVER ASSY: 5 X 8
6	08447-00002	PANEL :REAR
7	5060-0727	FOOT ASSY
8	08447-00001	PANEL:FRONT
9	5000-0710	COVER:BOTTOM 5 X 8 SM

See introduction to this section for ordering information

Table 6-3. Parts List Indexed by HP Part Number

Part No.	Description #	Mfr.	Mfr. Part No.	TQ
0150-0024	C:FXD CER 0.02 UF +80-20% 600VDCW	71590	TYPE DD 203	1
0160-0162	C:FXD MY 0.022 UF 10% 200VDCW	56289	192P22392-PTS	1
0160-2437	C:FXD CER 5000 PF +80-20% 200VDCW	72982	2425-000-X5V-502P	1
0180-0116	C:FXD ELECT 6.8 UF 10% 35VDCW	28480	0180-0116	1
0180-0228	C:FXD ELECT 22 UF 10% 15VDCW	28480	0180-0228	1
0180-1819	C:FXD ELECT 100 UF +75-10% 50VDCW	28480	0180-1819	1
0180-2272	C:FXD ELECT 850 UF +50-10% 75VDCW	56289	36D851F075AA2A DQB	1
0683-2735	R:FXD COMP 27K OHM 5% 1/4W	01121	CB 2735	1
0698-0083	R:FXD MET FLM 1.96K OHM 1% 1/8W	14674	C4	1
0698-3101	R:FXD MET FLM 2.87K OHM 1% 1/2W	28480	0698-3101	1
0698-3440	R:FXD MET FLM 196 OHM 1% 1/8W	91637	MF-1/10-32	1
0698-3442	R:FXD MET FLM 237 OHM 1% 1/8W	28480	0698-3442	1
0757-0278	R:FXD MET FLM 1.78K OHM 1% 1/8W	28480	0757-0278	1
0757-0290	R:FXD MET FLM 6.19K OHM 1% 1/8W	28480	0757-0290	1
0757-0416	R:FXD MET FLM 511 OHM 1% 1/8W	14674	C4	1
0757-0837	R:FXD MET FLM 8.25K OHM 1% 1/2W	28480	0757-0837	1
0757-0839	R:FXD MET FLM 10K OHM 1% 1/2W	28480	0757-0839	1
0757-1094	R:FXD MET FLM 1.47K OHM 1% 1/8W	28480	0757-1094	1
0811-16b8	R:FXO WW 1.5 OHM 5% 2W	28480	0811-1668	1
0900-0016	"O" RING:11/16"	28480	0900-0016	1
1200-0041	SOCKET:TRANSISTOR	71785	133-32-10-013	1
1200-0043	INSULATOR:TRANSISTOR MOUNTING	71785	293011	1
1210-0013	BRACKET:MOUNTING FOR 1-3/8 OD	56289	4586-87A	1
1251-0185	CONNECTOR:BODY 15 PIN	28480	1251-0135	1
1251-2357	CONNECTOR:AC POWER 3 MALE CONTACTS	82389	EAC-301	1
1400-0084	FUSEHOLDER:EXTRACTOR POST TYPE	79515	342014	1
1820-0169	INTEGRATED CIRCUIT:PRE-AMP 0.2-400MHZ	28480	1820-0169	2
1853-0012	Q:SI PNP	04713	2N2904A	1
1854-0022	Q:SI NPN	07263	S17843	1
1854-0063	O:SI NPN	04713	2N3055	1
1854-0071	O:SI NPN(SELECTED FROM 2N3704)	28480	1854-0071	3
1884-0012	RECTIFIER:SILICON CONTROLLED 2N3528	02735	2N3528	1
1901-0025	DIODE:SILICON 100MA/1V	07263	FD 2387	2
1901-0159	DIODE:SILICON 0.75A 400PIV	04713	SR1358-4	4
1902-0761	DIODE:BREAKDOWN 5.9 TO 6.5V	12954	1N821	1
1902-3036	DIODE BREAKDOWN:SILICON 3.16V	28480	1902-3036	1
1902-3290	DIODE BREAKDOWN:SILICON 31.6V 5%	28480	1902-3290	1
2100-1758	R:VAR WW 1K OHM 5% TYPE V 1W	28480	2100-1758	1
2110-0012	FUSE:CARTRIDGE 0.5A(230V OPERATION)	28480	2110-0012	2
2110-0269	CLIP:FUSE 0.250" DIA	91506	6008-32CN	1
2140-0244	LAMP:GLOW MINIATURE 95V	87034	A1H	1
2190-0037	WASHER:LOCK SST FOR 1/2 THREAD	78189	1224-08	1
2950-0038	NUT:HEX SST 1/2-24 X 11/16	75915	903-12	1
3101-1234	SIITCH:SLIDE DPDT	82389	11A-1242	1
3101-1244	SWITLH:PUSHBUTTON SPDT-DB	87034	53-55480-120/A1H	1
5000-0710	COVER:BOTTOM 5 X 8 SM	28480	5000-0710	1
5000-7891	SIDE COVER:3 X 8	28480	5000-7891	2
5060-0247	FRAME ASSY	28480	5060-0247	2
5060-0708	TOP COVER ASSY:5 X 8	28480	5060-0708	1
5060-0727	FOOT ASSY	28480	5060-0727	2
8120-1348	CABLE ASSY:POWER, DETACHABLE	70903	KHS-7041	1
9100-2894	TRANSFORMER:POWER	28480	9100-2894	1
08447-00001	PANEL:FRONT	28480	08447-00001	1

See introduction to this section for ordering information

Table 6-3. Parts List Indexed by HP Part Number (contd)

 Part No.	Description #	Mfr.	Mfr. Part No.	TQ
08447-00002	PANEL: REAR	28480	08447-00002	1
08447-00003	DECK: MAIN	28480	08447-00003	1
08447-20001	BOARD: BLANK PC	28480	08447-20001	1
08447-60001	BOARD ASSY: POWER SUPPLY	28480	08447-60001	1
08447-60003	CABLE ASSY: OUTPUT	28480	08447-60003	4

See introduction to this section for ordering information

Table 6-4. Code List of Manufacturers

The following code numbers are from the Federal Supply Code for Manufacturers Cataloging Handbooks H4-1 (Name to Code) and H4-2 (Code to Name) and their latest supplements. The date of revision and the date of the supplements used appear at the bottom of each page. Alphabetical codes have been arbitrarily assigned to suppliers not appearing in the H4 Handbooks.

Code No.	Manufacturer	Address	Code No.	Manufacturer	Address
00000	U.S.A Common	Any supplier of U.S.	05347	Ultronix, Inc.	San Mateo, Cal.
00136	McCoy Electronics	Mount Holly Springs, Pa	05397	Union Carbine Corp., Elect. Div.	New York, N.Y.
00213	Sage Electronics Corp.	Rochester, N.Y.	05574	Viking Ind. Inc.	Canoga Park, Cal.
00287	Cemco, Inc.	Danielson, Conn	05593	Icore Electro-Plastics Inc.	Sunnyvale, Cal.
00334	Humidial	Colton, Calif.	05616	Cosmo Plastic (c/o Electrical Spec. Co.)	Cleveland, Ohio
00348	Mictron, Co., Inc.	Valley Stream, N.Y	05624	Barber Colman Co.	Rockford, Ill.
00373	Garlock Inc.	Cherry Hill, N.J.	05728	Tiffen Optical Co.	Roslyn Heights, Long Island, N.Y.
00656	Aerovox Corp.	New Bedford, Mass.	05729	Metro-Tel Corp.	Westbury, N.Y.
00779	Amp. Inc.	Harrisburg, Pa.	05783	Stewart Engineering Co.	Santa Cruz, Cal.
00781	Aircraft Radio Corp.	Boonton, N.J.	05820	Wakefield Engineering Inc.	Wakefield, Mass.
00809	Croven.Ltd.	Whitby, Ontario, Canada	06004	Bassick Co., Div. of Stewart Warner Corp.	Bridgport, Conn.
00815	Northern Engineering Laboratories, Inc.	Burlington, Wis.	06090	Raychem Corp.	Redwood City, Cal.
00853	Sangamo Electric Co., Pickens Div.	Pickens, S.C	06175	Bausch and Lomb Optical Co.	Rochester, N.Y.
00866	Goe Engineering Co.	City of Industry, Cal.	06402	E.T.A. Products Co. of America	Chicago, Ill.
00891	Carl E. Holmes Corp.	Los Angeles, Cal.	06540	Amatom Electronic Hardware Co., Inc.	New Rochelle, N.Y.
00929	Microlab Inc.	Livingston, N.J.	06555	Beede Electrical Instrument Co., Inc.	Penacook, N.H.
01002	General Electric Co., Capacitor Dept.	Hudson Falls, N.Y.	06666	General Devices Co., Inc.	Indianapolis, Ind.
01009	Alden Products Co.	Brockton, Mass.	06751	Components Inc., Ariz. Div.	Phoenix, Arizona
01121	Allen Bradley Co.	Milwaukee, Wis.	06812	Torrington Mfg. Co., West Div.	Van Nuys, Cal.
01255	Litton Industries, Inc.	Beverly Hills, Cal.	06980	Varian Assoc. Etmac Div	San Carlos, Cal.
01281	TRW Semiconductors, Inc.	Lawndale, Cal.	07088	Kelvin Electric Co.	Van Nuys, Cal.
01295	Texas Instruments, Inc., Transistor Products Div.	Dallas, Texas	07126	Digitran Co.	Pasadena, Cal.
01349	The Alliance Mfg. Co.	Alliance, Ohio	07137	Transistor Electronics Corp.	Minneapolis, Minn.
01538	Small Parts Inc.	Los Angeles, Cal.	07138	Westinghouse Electric Corp., Electronic Tube Div.	Elmira, N.Y.
01589	Pacific Relays, Inc.	Van Nuys, Cal.	07149	Filmohm Corp.	New York, N.Y.
01670	Gudebrod Bros. Silk Co.	New York, N.Y.	07233	Cinch-Graphik Co.	City of Industry, Cal.
01930	Amerock Corp.	Rockford, Ill	07256	Silicon Transistor Corp.	Carle Place, N.Y.
01960	Pulse Engineering Co.	Santa Clara, Cal.	07261	Avnet Corp.	Culver City, Cal.
02114	Ferrocube Corp. of America	Saugerties, N.Y.	07263	Fairchild Camera & Inst. Corp., Semiconductor Div.	Mountain View, Cal.
02116	Wheelock Signals, Inc.	Long Branch, N.J.	07322	Minnesota Rubber Co.	Minneapolis, Minn.
02286	Cole Rubber and Plastics Inc.	Sunnyvale, Cal.	07387	Birtcher Corp, The	Monterey Park, Cal.
02660	Amphenol-Borg Electronics Corp.	Broadview, Ill	07397	Sylvania Elect. Prod. Inc., Mt. View Operations	Mountain View, Cal.
02735	Radio Corp. of America, Semiconductor and Materials Division	Somerville, N.J.	07700	Technical Wire Products Inc.	Cranford, N.J.
02771	Vocaline Co. of America, Inc.	Old Saybrook, Conn.	07829	Bodine Elect. Co.	Chicago, Ill.
02777	Hopkins Engineering Co.	San Fernando, Cal.	07910	Continental Device Corp	Hawthorne, Cal.
02875	Hudson Tool & Die	Newark, N.J	07933	Raytheon Mfg. Co., Semiconductor Div.	Mountain View, Cal.
03508	G.E. Semiconductor Prod. Dept.	Syracuse, N.Y.	07980	Hewlett-Packard Co., Boonton Radio Div.	Rockaway, N.J.
03705	Apex Machine & Tool Co.	Dayton, Ohio	08145	U.S. Engineering Co	Los Angeles, Cal.
03797	Eldema Corp.	Compton, Calif.	08289	Blinn, Delbert Co.	Pomona, Cal.
03818	Parker Seal Co.	Los Angeles, Cal.	08358	Burgess Battery Co.	Niagara Falls, Ontario, Canada
03877	Transitron Electric Corp.	Wakefield, Mass	08524	Deutsch Fastener Corp.	Los Angeles, Cal.
03888	Pyrofilm Resistor Co., Inc.	Cedar Knolls, N.J.	08664	Bristol Co., The	Waterbury, Conn.
03954	Singer Co., Diehl Div., Finderne Plant	Sumerville, N.J.	08717	Sloan Company	Sun Valley, Cal.
04009	Arrow, Hart and Hegeman Elect. Co.	Hartford, Conn.	08718	ITT Cannon Electric Inc., Phoenix Div.	Phoenix, Arizona
04013	Tamruus Corp.	Lambertville, N.J.	08727	National Radio Lab. Inc.	Paramus, N.J.
04062	Arco Electronic Inc.	Great Neck, N.Y.	08792	CBS Electronics Semiconductor Operations, Div. of CBS Inc.	Lowell, Mass.
04217	Essex Wire	Los Angeles, Cal.	08806	General Electric Co., Miniature Lamp Dept.	Cleveland, Ohio
04222	Hi-Q Division of Aerovox	Myrtle Beach, S.C.	08984	Mel-Rain	Indianapolis, Ind.
04354	Precision Paper Tube Co.	Wheeling, Ill.	09026	Babcock Relays Div	Costa Mesa, Cal.
04404	Dymec Division of Hewlett-Packard Co.	Palo Alto, Cal.	09134	Texas Capacitor Co.	Houston, Texas
04651	Sylvania Electric Products, Microwave Device Div.	Mountain View, Cal.	09145	Tech. Ind. Inc. Atohm Elect.	Burbank, Cal.
04673	Dakota Engr. Inc.	Culver City, Cal.	09250	Electro Assemblies, Inc.	Chicago, Ill.
04713	Motorola Inc, Semiconductor Prod. Div.	Phoenix, Arizona	09353	C & K Components Inc.	Newton, Mass.
04732	Filtron Co., Inc. Western Div.	Culver City, Cal.	09569	Mallory Battery Co. of Canada, Ltd.	Toronto, Ontario, Canada
04773	Automatic Electric Co.	Northlake, Ill.	09922	Burndy Corp	Norwalk, Conn.
04796	Sequoia Wire Co.	Redwood City, Cal.	10214	General Transistor Western Corp.	Los Angeles, Cal.
04811	Precision Coil Spring Co.	El Monte, Cal.			
04870	P. M. Motor Company	Westchester, Ill.			
04919	Component Mfg. Service Co	W. Bridgewater, Mass.			
05006	Twentieth Century Plastics, Inc.	Los Angeles, Cal.			
05277	Westinghouse Electric Corp. Semiconductor Dept.	Youngwood, Pa.			

00015-46

Revised: October 1969

From: Handbook Supplements
H4-1 Dated AUGUST 1966

Table 6-4. Code List of Manufacturers (contd)

Code No.	Manufacturer	Address	Code No.	Manufacturer	Address
10411	Ti-Tal, Inc.	Berkeley, Cal.	19589	Concoa	Baldwin Park, Cal.
10646	Carborundum Co.	Niagara Falls, N.Y.	19644	LRC Electronics	Horseheads, N.Y.
11236	CTS of Berne, Inc.	Berne, Ind.	19701	Electra Mfg. Co.	Independence, Kansas
11237	Chicago Telephone of California, Inc.		20183	General Atronics Corp.	Philadelphia, Pa.
		So. Pasadena, Cal.	21226	Executone, Inc.	Long Island City, N.Y.
11242	Bay State Electronics Corp.	Waltham, Mass.	21355	Fafnir Bearing Co., The	New Britain, Conn.
11312	Teledyne Inc., Microwave Div.	Palo Alto, Cal.	21520	Fansteel Metallurgical Corp.	N. Chicago, Ill.
11314	National Seal	Downey, Cal.	23042	Texscan Corp.	Indianapolis, Ind.
11453	Precision Connector Corp.	Jamaica, N.Y.	23783	British Radio Electronics Ltd.	Washington, D.C.
11534	Duncan Electronics Inc.	Costa Mesa, Cal.	24455	G.E. Lamp Division	Nela Park, Cleveland, Ohio
11711	General Instrument Corp., Semiconductor Division, Products Group	Newark, N.J.	24655	General Radio Co.	West Concord, Mass.
			24681	Memcor Inc., Comp. Div.	Huntington, Ind.
11717	Imperial Electronic, Inc.	Buena Park, Cal.	26365	Gries Reproducer Corp.	New Rochelle, N.Y.
11870	Melabs., Inc.	Palo Alto, Cal.	26462	Grobert File Co. of America, Inc.	Carlstadt, N.J.
12136	Philadelphia Haulde Co.	Camden, N.J.	26851	Compac/Hollister Co.	Hollister, Cal.
12361	Grove Mfg. Co., Inc.	Shady Grove, Pa.	26992	Hamilton Watch Co.	Lancaster, Pa.
12574	Gulton Ind. Inc., Data System Div.	Albuquerque, N.M.	28480	Hewlett-Packard Co.	Palo Alto, Cal.
12697	Clarostat Mfg. Co.	Dover, N.H.	28520	Heyman Mfg. Co.	Kenilworth, N.J.
12728	Elmar Filter Corp.	W. Haven, Conn.	30817	Instrument Specialties Co., Inc.	Little Falls, N.J.
12859	Nippon Electric Co., Ltd.	Tokyo, Japan	33173	G.E. Receiving Tube Dept.	Owensboro, Ky.
12881	Metex Electronics Corp.	Clark, N.J.	35434	Lectrohm Inc.	Chicago, Ill.
12930	Delta Semiconductor Inc.	Newport Beach, Cal.	36196	Stanwyck Coil Products, Ltd.	
12954	Dickson Electronics Corp.	Scottsdale, Arizona			Hawkesbury, Ontario, Canada
13019	Airco Supply Co., Inc.	Wichita, Kansas	36287	Cunningham, W.II. & Hill, Ltd.	
13103	Thermolov	Dallas, Texas			Toronto, Ontario, Canada
13396	Telefunken (GmbH)	Hanover, Germany	37942	P.R. Mallory & Co., Inc.	Indianapolis, Ind.
13835	Mittland-Wright Div. of Pacific Industries, Inc.	Kansas City, Kansas	39543	Mechanical Industries Prod. Co.	Akron, Ohio
			40920	Miniature Precision Bearings, Inc.	Keene, N.H.
14099	Sem-Tech	Newbury Park, Cal.	42190	Muter Co.	Chicago, Ill.
14193	Calif. Resistor Corp.	Santa Monica, Cal.	43990	C.A. Norgren Co.	Englewood, Colo.
14298	American Components, Inc.	Conshohocken, Pa.	44655	Ohmite Mfg. Co.	Skokie, Ill.
14433	ITT Semiconductor, A Div. of Int. Telephone & Telegraph Corporation	West Palm Beach, Fla.	46384	Penn Eng. & Mfg. Corp.	Doylestown, Pa.
			47904	Polaroid Corp.	Cambridge, Mass.
14493	Hewlett-Packard Company	Loveland, Colo.	48620	Precision Thermometer & Inst. Co.	Southampton, Pa.
14655	Cornell Dublier Electric Corp.	Newark, N.J.	49956	Microwave & Power Tube Div.	Waltham, Mass.
14674	Corning Glass Works	Corning, N.Y.	52090	Rowan Controller Co.	Westminster, Md.
14752	Electro Cube Inc.	San Gabriel, Cal.	52983	Sanborn Company	Waltham, Mass.
14960	Williams Mfg. Co.	San Jose, Cal.	54294	Shallcross Mfg. Co.	Selma, N.C.
15106	The Sphere Co., Inc.	Little Falls, N.J.	55026	Simpson Electric Co.	Chicago, Ill.
15203	Webster Electronics Co.	New York, N.Y.	55933	Sonotone Corp.	Elmsford, N.Y.
15287	Scionics Corp.	Northridge, Cal.	55938	Raytheon Co. Commercial Apparatus & System Div.	
15291	Adjustable Bushing Co.	N. Hollywood, Cal.			So. Norwalk, Conn.
15558	Micron Electronics	Garden City, Long Island, N.Y.	56137	Spaulding Fibre Co., Inc.	Tonawanda, N.Y.
15566	Amprobe Inst. Corp.	Lynbrook, N.Y.	56289	Sprague Electric Co.	North Adams, Mass.
15631	Cabletronics	Costa Mesa, Cal.	59446	Telex Corp.	Tulsa, Okla.
15772	Twentieth Century Coil Spring Co.	Santa Clara, Cal.	59730	Thomas & Belts Co.	Elizabeth, N.J.
15801	Fenwal Elect. Inc.	Framingham, Mass.	60741	Triplett Electrical Inst. Co.	Bluffton, Ohio
15818	An,elco Inc.	Mountain View, Cal.	61775	Union Switch and Signal, Div. of Westinghouse Air Brake Co.	Pittsburgh, Pa.
16037	Spruce Pine Mica Co.	Spruce Pine, N.C.			Owosso, Mich.
16179	Omni-Spectra Inc.	Detroit, 111.	62119	Universal Electric Co.	Owosso, Mich.
16352	Computer Diode Corp.	Lodi, N.J.	63743	Ward-Leonard Electric Co.	Mt. Vernon, N.Y.
16585	Boots Aircraft Nut Corp.	Pasadena, Cal.	64959	Western Electric Co., Inc.	New York, N.Y.
16688	Ideal Prec. Meter Co., Inc. De Jur Meter Div.65092				Newark, N.J.
		Brooklyn, N.Y.	66295	Weston Inst. Inc. Weston-Newark	Chicago, Ill.
16758	Delco Radio Div. of G.M. Corp.	Kokoma, Ind.	66346	Wittek Mfg. Co.	Chicago, Ill.
17109	Thermonetics Inc.	Canoga Park, Cal.			St. Paul, Minn.
17474	Tranex Company	Mountain View, Cal.	70276	Allen Mfg. Co.	Hartford, Conn.
17675	Hamlin Metal Products Corp.	Akron, Ohio	70309	Allied Control	New York, N.Y.
17745	Angstrom Prec. Inc.	No. Hollywood, Cal.	70318	Allmetal Screw Product Co. Inc.	Garden City, N.Y.
17856	Siliconix Inc.	Sunnyvale, Cal.	70417	Amplex, Div. of Chrysler Corp.	Deiroit, Mich.
17870	McGraw-Edison Co.	Manchester, N.H.	70485	Atlantic India Rubber Works, Inc.	Chicago, Ill.
18042	Power Design Pacific Inc.	Palo Alto, Cal.	70563	Amperite Co., Inc.	Union City, N.J.
18083	Clevite Corp., Semiconductor Div.	Palo Alto, Cal.	70674	ADC Products Inc.	Minneapolis, Minn.
18324	Signetics Corp.	Sunnyvale, Cal.	70903	Belden Mfg. Co.	Chicago, Ill.
18476	Ty-Car Mfg. Co., Inc.	Holliston, Mass.	70998	Bird Electric Corp.	Cleveland, Ohio
18486	TRW Elect. Comp. Div.	Des Plaines, 111.I	71002	Blimbach Radio Co.	New York, N.Y.
18583	Curtis Instrument, Inc.	Mr. Kisco, N.Y.	71034	Bliley Electric Co., Inc.	Erie, Pa.
18612	Vishay Instruments Inc.	Malvern, Pa.	71041	Boston Gear Works Div. of Murray Co. of Texas	
18873	E.I. DuPont and Co., Inc.	Wilmington, Del.			Quincey, Mass.
18911	Durant Mfg. Co.	Milwaukee, Wis.	71218	Bud Radio, Inc.	Willoughbv, Ohio
19315	The Bendix Corp., Navigation & Control Div.		71279	Cambridge Thermionict Corp.	Cambridge, Mass.
		Teterboro, N.J.	71286	Camloc Fastener Corp.	Paramus, N.J.
19500	Thomas A. Edison Industries, Div. of McGraw-Edison Co.	West Orange, N.J.	71313	Cardwell Condenser Corp.	Lindenhurst, L.I., N.Y.
			71400	Bussmann Mfg. Div. of McGraw Edison Co.	St. Louis, Mo.

00015-46
Revised: October 1969

From: Handbook Supplements
H4-1 Dated AUGUST 1966

Table 6-4. Code List of Manufacturers (contd)

Code No.	Manufacturer	Address	Code No.	Manufacturer	Address
71436	Chicago Condenser Corp.	Chicago, Ill.	77764	Resistance Products Co.	Harrisburg, Pa.
71447	Calif. Spring Co., Inc.	Pico-Rivera, Cal.	77969	Rubbercraft Corp. of Calif.	Torrance, Cal.
71450	CTS Corp.	Elkhart, Ind.	78189	Shakeproof Division of Illinois Tool Works	Elgin, Ill.
71468	ITT Cannon Electric Inc.	Los Angeles, Cal.	78277	Sigma	So. Braintree, Mass.
71471	Cinema, Div. Aerovox Corp.	Burbank, Cal.	78283	Signal Indicator Corp.	New York, N.Y.
71482	C.P. Clare & Co.	Chicago, Ill.	78290	Struthers-Dunn Inc.	Pitman, N.J.
71590	Centralab Div. of Globe Union Inc.	Milwaukee, Wis.	78452	Thompson-Bremer & Co.	Chicago, Ill.
71616	Commercial Plastics Co.	Chicago, Ill.	73471	Tilley Mfg. Co.	San Francisco, Cal.
71700	Cornish Wire Co., The	New York, N.Y.	78488	Stackpole Carbon Co.	St. Marys, Pa.
71707	Coto Coil Co., Inc.	Providence, R.I.	78493	Standard Thomson Corp.	Waltham, Mass.
71744	Chicago Miniature Lamp Works	Chicago, Ill.	78553	Tinnerman Products, Inc.	Cleveland, Ohio
71785	Cinch Mfg. Co., Howard B. Jones Div.	Chicago, Ill.	78790	Transformer Engineers	San Gabriel, Cal.
71984	Dow Corning Corp.	Midland, Mich.	78947	Ucinite Co.	Newtonville, Mass.
72136	Electro Motive Mfg. Co., Inc.	Willimantic, Conn.	79136	Waldes Kohinoor Inc.	Long Island City, N.Y.
72619	Dialight Corp.	Brooklyn, N.Y.	79142	Veeder Root, Inc.	Hartford, Conn.
72656	Indiana General Corp., Electronics Div.	Keasby, N.J.	79251	Wenco Mfg. Co.	Chicago, Ill.
72699	General Instrument Corp., Cap. Div.	Newark, N.J.	79727	Continental-Wirt Electronics Corp.	Philadelphia, Pa.
72765	Drake Mfg. Co.	Harwood Heights, Ill.	79963	Zierick Mfg. Corp.	New Rochelle, N.Y.
72825	Hugh H. Eby Inc.	Philadelphia, Pa.	80031	Mepco Division of Sessions Clock Co.	Morrisstown, N.J.
72928	Gudeman Co.	Chicago, Ill.	80033	Prestole Corp.	Toledo, Ohio
72962	Elastic Stop Nut Corp.	Union, N.J.	80120	Schnitzer Alloy Products Co.	Elizabeth, N.J.
72964	Robert M. Hadley Co.	Los Angeles, Cal.	86131	Electronic Industries Association. Any Brand Tube meeting EIA Standards-Washington, D.C.	
72982	Erie Technological Products, Inc.	Erie, Pa.	80207	Unimax Switch, Div. Maxon Electronics Corp.	Wallingford, Conn.
73061	Hansen Mfg. Co., Inc.	Princeton, Ind.	80223	United Transformer Corp.	New York, N.Y.
73076	H.M. Harper Co.	Chicago, Ill.	80248	Oxford Electric Corp.	Chicago, Ill.
73138	Helipot Div. of Beckman Inst. Inc.	Fullerton, Cal.	80294	Bourns Inc.	Riverside, Cal.
73293	Hughes Products Division of Hughes Aircraft Co.	Newport Beach, Cal.	80411	Arco Div. of Robertshaw Controls Co.	Columbus, Ohio
73445	Amperex Elect. Co.	Hicksville, L.I., N.Y.	80486	All Star Products Inc.	Defiance, Ohio
73506	Bradley Semiconductor Corp.	New Haven, Conn.	80509	Avery Label Co.	Monrovia, Cal.
73559	Carling Electric, Inc.	Hartford, Conn.	80583	Hammarlund Co., Inc.	Mars Hill, N.C.
73586	Circle F Mfg. Co.	Trenton, N.J.	80640	Stevens, Arnold, Co., Inc.	Boston, Mass.
73682	George K. Garrett Co., Div. MSL Industries Inc.	Philadelphia, Pa.	80813	Dimco Gray Co.	Dayton, Ohio
73734	Federal Screw Products Inc.	Chicago, Ill.	81030	International Instruments Inc.	Orange, Conn.
73743	Fischer Special Mfg. Co.	Cincinnati, Ohio	81073	Grayhill Co.	LaGrange, Ill.
73793	General Industries Co., The	Elyria, Ohio	81095	Triad Transformer Corp.	Venice, Cal.
73846	Goshen Stamping & Tool Co.	Goshen, Ind.	81312	Winchester Elec. Div. Litton Ind. Inc.	Oakville, Conn.
73899	JFD Electronics Corp.	Brooklyn, N.Y.	81349	Military Specification	
73905	Jennings Radio Mfg. Corp.	San Jose, Cal.	81483	International Rectifier Corp.	El Segundo, Cal.
73957	Groove-Pin Corp.	Ridgefield, N.J.	81541	Airpax Electronics, Inc.	Cambridge, Maryland
74276	Signalite Inc.	Neptune, N.J.	81860	Barry Controls, Div. Barry Wright Corp.	
74455	J.H. Winns, and Sons	Winchester, Mass.	82042	Carter Precision Electric Co.	Skokie, Ill.
74861	Industrial Condenser Corp.	Chicago, Ill.	82047	Sperti Faraday Inc., Copper Hewitt Electric Div.	Hoboken, N.J.
74868	R.F. Products Division of Amphenol-Borg Electronics Corp.	Danbury, Conn.	82116	Electric Regulator Corp.	Norwalk, Conn.
74970	E.F. Johnson Co.	Waseca, Minn.	82142	Jeffers Electronics Division of Speer Carbon Co.	Du Bois, Pa.
75042	International Resistance Co.	Philadelphia, Pa.	82170	Fairchild Camera & Inst. Corp., Space & Defense Systems Div.	Paramus, N.J.
75263	Keystone Carbon Co., Inc.	St. Marys, Pa.	82209	Magurie Industries, Inc.	Greenwich, Conn.
75378	CTS Knights Inc.	Sandwich, Ill.	82219	Sylvania Electric Prod. Inc., Electronic Tube Division	Emporium, Pa.
75382	Kulka Electric Corporation	Mt. Vernon, N.Y.	82376	Astron Corp.	East Newark, Harrison, N.J.
75818	Lenz Electric Mfg. Co.	Chicago, Ill.	82389	Switchcraft, Inc.	Chicago, Ill.
75915	Littlefuse, Inc.	Des Plaines, Ill.	82647	Metals & Controls Inc., Spencer Products	Attleboro, Mass.
76005	Lord Mfg. Co.	Erie, Pa.	82768	Phillips-Advance Control Co.	Joliet, Ill.
76210	C.W. Marwedel	San Francisco, Cal.	82866	Research Products Corp.	Madison, Wis.
76433	General Instrument Corp.	Micamold Division Newark, N.J.	82877	Rolltron Mfg. Co., Inc.	Woodstock, N.Y.
76487	James Milen Mfg. Co., Inc.	Malden, Mass.	82893	Vector Electronic Co.	Glendale, Cal.
76493	J.W. Miller Co.	Los Angeles, Cal.	83058	Carr Fastener Co.	Cambridge, Mass.
76530	Cinch-Monadnock, Div. of United Carr Fastener Corp.	San Leandro, Cal.	83086	New Hampshire Ball Bearing, Inc.	Peterborough, N.H.
76545	Mueller Electric Co.	Cleveland, Ohio	83125	General Instrument Corp., Capacitor Div.	Darlington, S.C.
76703	National Union	Newark, N.J.	83148	ITT Wire and Cable Div.	Los Angeles, Cal.
76854	Oak Manufacturing Co.	Crystal Lake, Ill.	83186	Victory Eng. Corp.	Springfield, N.J.
77068	The Bendix Corp., Electrodynamics Div.	N. Hollywood, Cal.	83298	Bendix Corp., Red Bank Div.	Red Bank, N.J.
77075	Pacific Metals Co.	San Francisco, Cal.	83315	Hubbell Corp.	Mundelein, Ill.
77221	Phanostran Instrument and Electronic Co.	So. Pasadena, Cal.	83324	Rosan Inc.	Newport Beach, Cal.
77252	Philadelphia Steel and Wire Corp.	Philadelphia, Pa.	83230	Smith, Herman H., Inc.	Brooklyn, N.Y.
77342	American Machine & Foundry Co. Potter & Brumfield Div.	Princeton, Ind.	83332	Tech Labs	Palisades Park, N.J.
77630	TRW Electronic Components Div.	Camden, N.J.	83385	Central Screw Co.	Chicago, Ill.
77638	General Instrument Corp., Rectifier Div.	Brooklyn, N.Y.			

SECTION VII
MANUAL CHANGES

7-1. Manual Changes.

7-2. Current Instruments.

7-3. This manual applies to standard Model 8447A Amplifier having the following serial prefix number 955:

7-4. Older Instruments.

7-5. This manual covers all instruments currently available. As instrument changes are made and this manual is revised, backdating information to cover older instruments will be included in this section.

7-6. Newer Instruments

7-7. As changes are made in the Model 8447A, newer instruments may have serial prefix numbers not listed in this manual. The manuals for these instruments will be supplied with an additional "Manual Changes" sheet containing the required information; contact your nearest Hewlett-Packard sales and service office for information if this sheet is missing.

7-1/(7-2 blank)

SECTION VIII

SERVICE

8-1. INTRODUCTION.

8-2. This section contains theory of operation, troubleshooting instructions, schematics and component locations for the Model 8447A Amplifier. Also included is general service information for semiconductors and printed circuits boards.

8-3. TROUBLESHOOTING.

8-4. Service Sheet 1 contains detailed troubleshooting information. In a few instances certain specific parts are called out as a probable cause of circuit malfunction, however, the troubleshooting charts are not intended to locate specific parts that have failed. They are intended to locate malfunctioning stages only.

8-5. SCHEMATICS.

8-6. The schematics contain signal-routing information, nominal voltage levels, waveforms and notes that assist in understanding the circuit. They show electrical operation and are not intended as wiring diagrams. Component location photographs next to the schematic fold-outs indicate the physical location of the parts. Test points are also shown in the photograph as well as on the schematic. Table 8-2, Schematic Notes, shows the test conditions that existed when the nominal voltages and the waveforms were observed.

8-7. TEST EQUIPMENT AND ACCESSORIES REQUIRED.

8-8. Test equipment and accessories required to troubleshoot the Model 8447A Amplifier are shown in Table 1-2. Test instruments other than those listed may be used provided that their specifications meet or exceed those listed in Table 1-2.

8-9. REPAIR.

8-10. The locations of chassis parts are shown in Figure 8-2. The location of individual printed circuit board components are shown on the service sheet page. The part reference designator is the assembly designator plus the part designator. (Example: A1R9 is R9 on the A1 Power Supply Assembly.) Refer to the parts list in Section VI for specific component description for ordering parts.

8-11. DIAGRAM NOTES.

8-12. Table 8-2, Schematic Notes, provide information relating to symbols and values shown in the schematic diagrams.

8-13. ETCHED CIRCUITS.

8-14. The etched circuit board in the Model 8447A is of the plated-through type consisting of metallic conductors bonded to both sides of insulating material. The metallic conductors are extended through the component mounting holes by a plating process. Soldering can be done from either side of the board with equally good results. Table 8-1 lists recommended tools and materials. Following are recommendations and precautions pertinent to etched circuit repair work.

a. Avoid unnecessary component substitution; it can result in damage to the circuit board and/or adjacent components.

b. Do not use a high-power soldering iron on etched circuit boards. Excessive heat may lift a conductor or damage the board.

c. Use a suction device (Table 8-1) or wooded toothpick to remove solder from component mounting holes. DO NOT USE A SHARP METAL OBJECT SUCH AS AN AWL OR TWIST DRILL FOR THIS PURPOSE. SHARP OBJECTS MAY DAMAGE THE PLATED-THROUGH CONDUCTOR.

d. After soldering, remove excess flux from the soldered areas and apply a protective coating to prevent contamination and corrosion. See Table 8-1 for recommendations.

8-15. Etched Conductor Repair. A broken or burned section of conductor can be repaired by bridging the damaged section with a length of tinned copper wire. Allow adequate overlap and remove any varnish from etched conductor before soldering wire into place.

8-16. COMPONENT REPLACEMENT.

a. Remove defective component from board.

NOTE

Axial lead components, such as resistors and tubular capacitors, can be replaced without unsoldering. Clip leads near body of defective component, remove component and straighten leads left in board. Wrap leads of replacement component one turn around original leads. Solder wrapped connection, and clip off excess lead.

b. If component was unsoldered, remove solder from mounting holes, and position component as original was positioned. DO NOT FORCE LEADS INTO MOUNTING HOLES; sharp lead ends may damage plated-through conductor.

8-17. TRANSISTOR REPLACEMENT.

8-18. Solid state transistors are in many physical forms. This sometimes results in confusion as to which lead is the collector, which is the emitter, and which is the base. Figure 8-1 shows epoxy and metal case transistors and the means of identifying the leads.

8-19. To replace the transistor proceed as follows:

- a. Do not apply excessive heat: see Table 8-1 for recommended soldering tools.
- b. Use long-nose pliers between transistor and hot soldering iron as a heat sink. The instant solder is melted, use pliers to pull lead free of board.
- c. When installing replacement transistor, ensure sufficient lead length to dissipate soldering heat by using about the same length of exposed lead as used for original transistor.

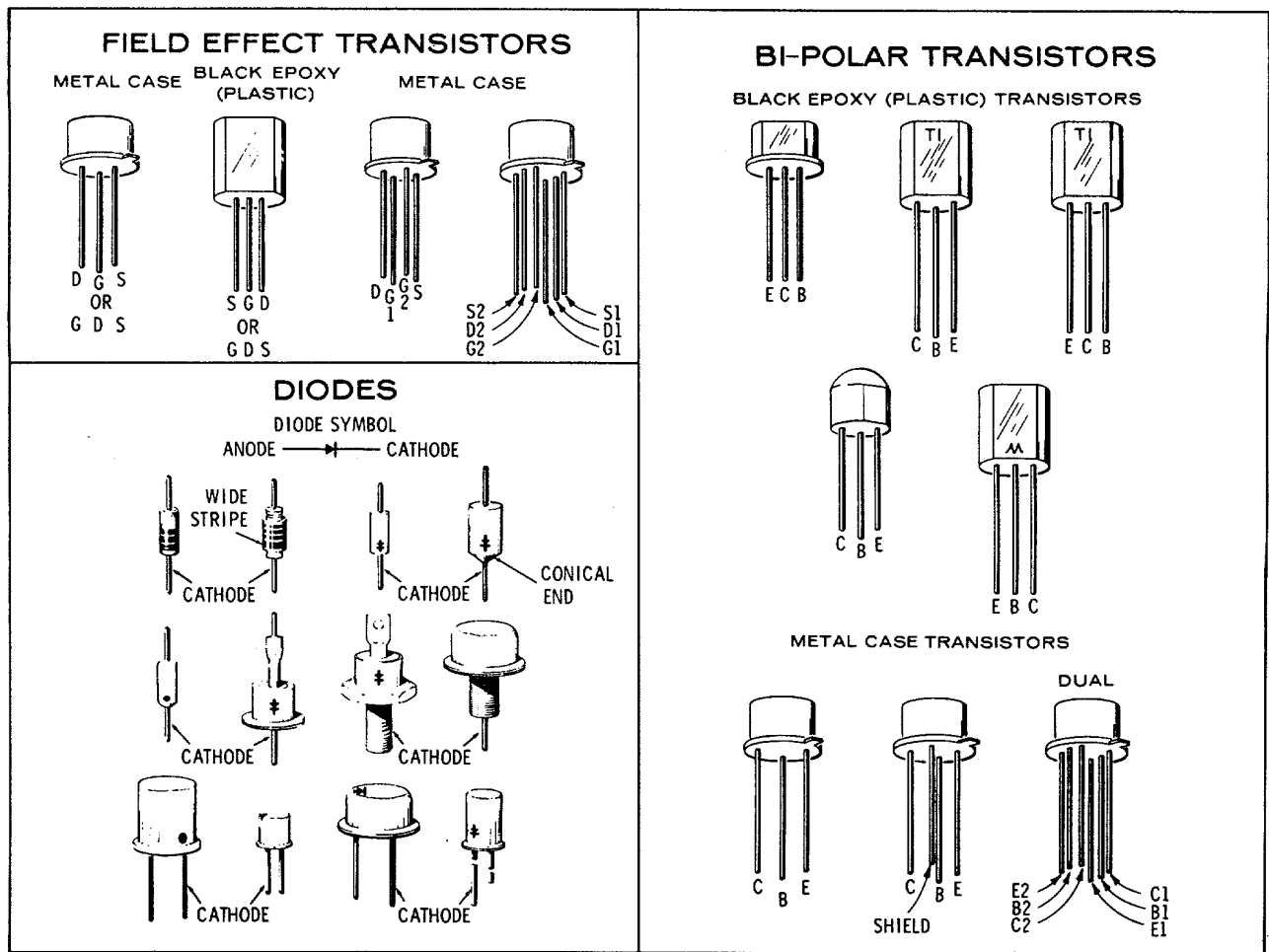

Figure 8-1. Examples of Diode and Transistor Marking Methods

Table 8-1. Etched Circuit Soldering Equipment

Item	Use	Specification	Item Recommended
Soldering tool	Soldering Unsoldering	Wattage rating: 47-1/2 -56-1/2 Tip Temp: 850 - 900° F	Ungar #776 Handle with *Ungar #4037 Heating Unit
Soldering*Tip	Soldering Unsoldering	*Shape: pointed	*Ungar #PL111
De-soldering aid	To remove molten solder from con- nection	Suction device	Soldapullt by Edsyn Co. Arleta, California
Resin (flux) solvent	Remove excess flux from soldered area before application of protective coating	Must not dissolve etched cir- cuit base board material or conductor bonding agent	Freon Acetone Lacquer Thinner Isopropyl Alcohol (100% dry)
Solder	Component re- placement Circuit board repair wiring	Resin (flux) core, high tin content (60/40 tin/lead), 18 gauge (SWG) preferred	
Protective	Contamination, corrosion pro- tection	Good electrical insulation, corrosion-prevention pro- perties	Krylon (R)** #1302 Humiseal Protective Coating, Type 1B12 by Columbia Technical Corp. Woodside 77, New York

*For working on 8447 Board: for general purpose work, use Ungar # 1237 Heating Unit (37.5W, tip temp of 750-800) and Ungar #PL113 1/8" chisel tip.

**Krylon, Inc., Norristown, Pennsylvania

8-20. Some transistors are mounted for good heat dissipation. This requires good thermal contact with mounting surfaces. To assure good thermal contact for a replacement transistor, coat both sides of the black insulator with Dow Corning #5 silicone compound or equivalent before fastening the transistor to the chassis. Dow Corning #5 compound is available in 8-oz tubes from Hewlett-Packard; order HP Part No. 8500-0059.

8-21. DIODE REPLACEMENT.

8-22. Solid state diodes are in many physical forms. This sometimes results in confusion as to which lead or connection is for the cathode (negative) or anode (positive), since not all diodes are marked with the standard symbols. Figure 8-1 shows examples of some diode marking methods. If doubt exists as to polarity, an ohmmeter may be used to determine the proper connection. It is necessary to know the polarity of the ohms lead with respect to the common lead for the ohmmeter used. (For the HP Model 410B Vacuum Tube Voltmeter, the ohms lead is negative with respect to the common; for the HP Model 412A DC Vacuum Tube Voltmeter, the ohms lead is positive with respect to the common.). When the ohmmeter indicates the least diode resistance, the cathode of the diode is connected to the ohmmeter lead which is negative with respect to the other lead.

NOTE

Replacement instructions are the same as those listed for transistor replacement.

8-3/(8-4 blank)

SCHEMATIC DIAGRAM NOTES

Refer to MIL Std 15B for Symbols Not Shown

Resistance is in ohms and capacitance is in microfarads unless otherwise noted.

P/O = part of.

*Asterisk denotes a factory-selected value. Value shown is typical. Capacitors may be omitted or resistors jumpered.















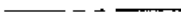

	Screwdriver adjustment.		Panel control.
	Encloses front panel designations.		Encloses rear panel designation.
	Circuit assembly borderline.		
	Other assembly borderline.		
	Heavy line with arrows indicates path and direction of main signal.		
	Heavy dashed line with arrows indicates path and direction of main feedback.		
	Wiper moves toward CW with clockwise rotation of control as viewed from shaft or knob.		
	Numbers in circles on circuit assemblies show locations of test points.		
	Encloses wire color code. Code used (MIL-STD-681) is the same as the resistor color code. First number identifies the base color, second number the wider stripe, and the third number identifies the narrower stripe. E.g., (947) denotes white base, yellow wide stripe, violet narrow stripe.		
	Voltage regulator (breakdown diode).		
	Denotes Field Effect transistor (FET) with N-type base.		
	Denotes FET with P-type base.		
	Denotes Capacitive diode (Varicap, varactor).		
	Denotes Silicon Controlled Rectifier.		
	P-Type Metal Oxide Substrate FET (MOSFET)		
	N-Type Metal Oxide Substrate FET (MOSFET)		

Table 8-2. Schematic Notes

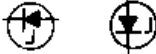
Table 8-3. Model 8447A Component and Assembly Locations

Assembly	Schematic	Photo
A1 Power Supply	Service Sheet 1	Figure 8-2
Component	Schematic	Photo
U1 RF Amplifier	Service Sheet 1	Figure 8-2
U2 RF Amplifier	Service Sheet 1	Figure 8-2
DS1	Service Sheet 1	Figure 8-2
F1 0.5 A Fuse	Service Sheet 1	Figure 8-4
A1F1 0.5 A Fuse	Service Sheet 1	Figure 8-4
A1R9 VOLT ADJ	Service Sheet 1	Figure 8-2
W1	Service Sheet 1	Figure 8-2
W2	Service Sheet 1	Figure 8-2
W3	Service Sheet 1	Figure 8-2
W4	Service Sheet 1	Figure 8-2
W5	Service Sheet 1	Figure 8-2

Model 8447A

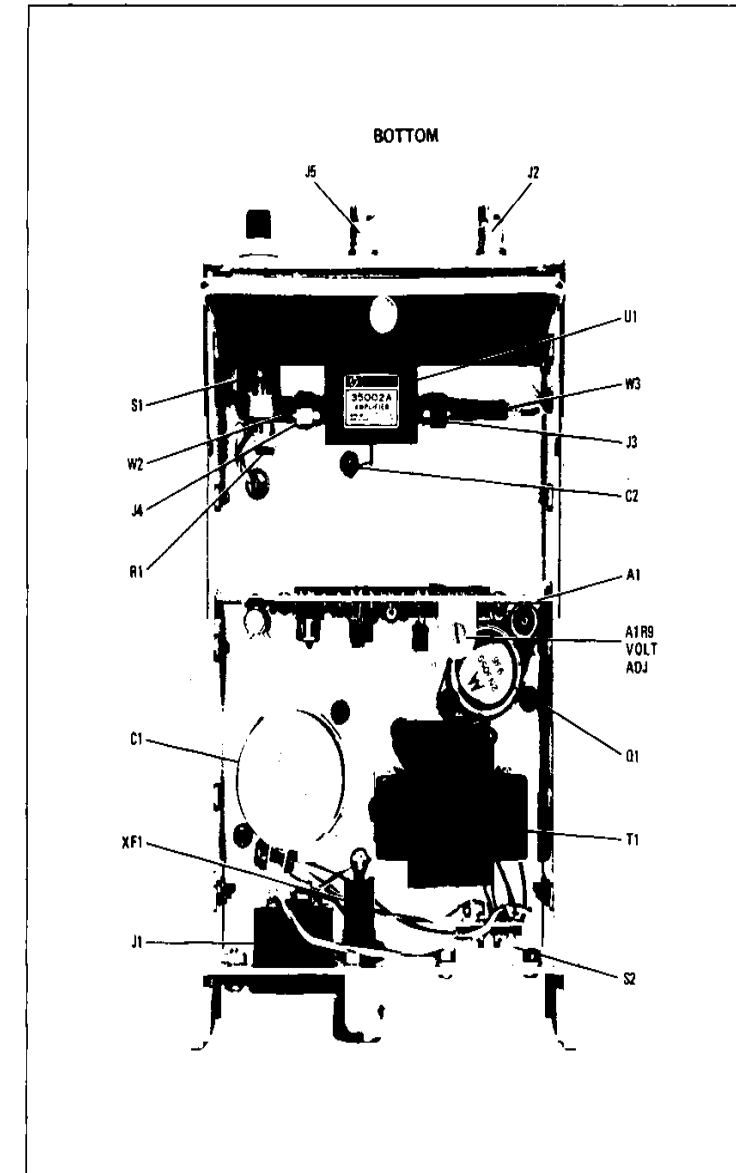
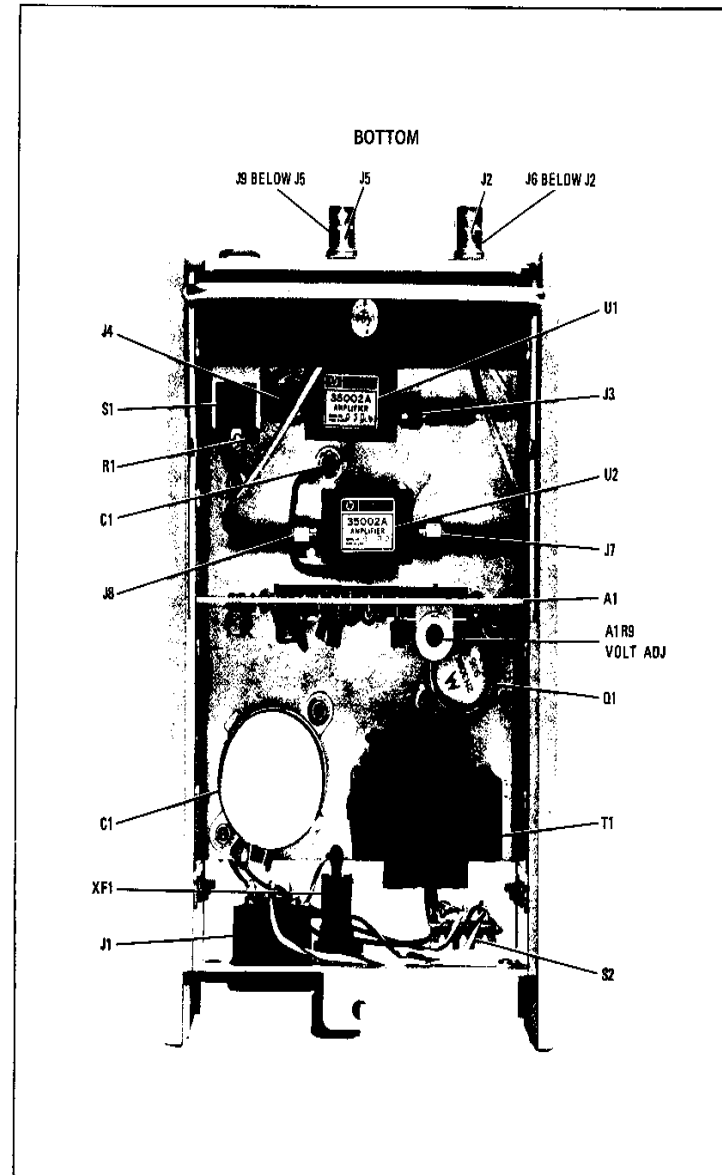
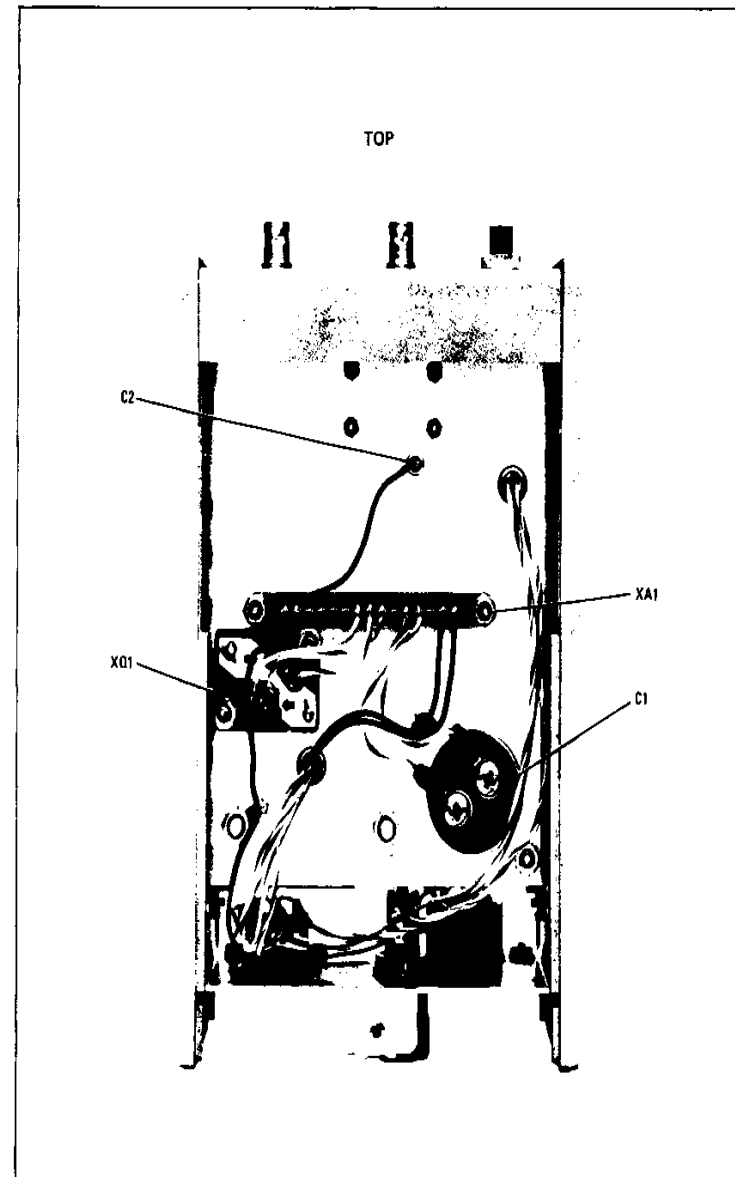

Figure 8-2. Models 8447A and 8447A-001 Dual Amplifier Component and Assembly Locations

SERVICE SHEET 1

It is assumed that the Model 8447A Amplifier does not meet the specifications of the performance test in Paragraph 4-6 through 4-9.

TROUBLESHOOTING PROCEDURE.

First check the input and output cables. Isolate trouble to the RF amplifier or power supply by checking the +28 volts at the amplifier circuit (Test Point 1). If the voltage is present, replace the amplifier. If voltage is not present or incorrect, check the power supply test procedure.

EQUIPMENT REQUIRED

Digital Voltmeter Voltmeter HP 3440A/3443A
 Volt-ohm-ammeter HP412A

1 RF AMPLIFIER.

The RF amplifier is a standard HP 38003A Hybrid Integrated Wide-Band amplifier. Gain of the amplifier can be controlled by changing the voltage applied to it.

2 POWER SUPPLY.

F1 protects the instrument against line surges and internal shorts. The primary winding of T1 are connected in parallel when S2 is in 115 position. When S2 is in the 230 position, T1 windings are connected in series.

Secondary voltage of T1 is full wave rectified by CR1, CR2, CR3, and CR4. This rectifier provides unregulated 50 volts. C1 helps filter the rectified voltage.

The +28 volt regulator consists of current source A1Q1, control amplifier A1Q2, series regulator Q1, comparison amplifier A1Q4 and A1Q5, and current limiter A1Q3. Comparison amplifier A1Q4 and A1Q5 compares the voltage at the base of A1Q5 (a voltage proportional to the +28 volt output) with a regulated voltage at the base of A1Q4. The regulated reference is established by A1CR6. Any difference between the voltage is used as an error voltage to control the conduction of Q1. This error voltage, which is coupled through A1Q2, changes the condition of Q1 to maintain a zero volt difference between the bases of A1Q4 and A1Q5. This action keeps the output voltage constant.

The current limiter, A1Q3, provides foldback limiting; that is where the short circuit current is less than the maximum current delivered by the series regulator. The point at which current limiting starts is determined by A1R3, A1R4 and A1R12. If the load resistance drops to a low value, A1Q3 turns on, reducing drive to A1Q2. This in turn reduces the conduction of Q1, reducing the output voltage and limiting current.

The silicon controlled rectifier, A1CR9, acts as a switch to protect the amplifier in the event of a shorted series regulator. If the series regulator shorts, the output voltage would increase to approximately 60 volts. At about 32 V, A1CR9 turns on. This shorts the output to approximately zero and blows fuse F1.

TROUBLE SHOOTING PROCEDURE 1

Check power supply voltage in pin 14 of XA1. If voltage is +28 volts ± 0.1 volts the trouble exists in the amplifier feedthrough, or cables.

Check the voltage in the power supply input pin of the microcircuit amplifier U1. If voltage is present, check the input and output cables. If the voltage is present and the cables are good the trouble is in the microcircuit amplifier and should be replaced.

TROUBLESHOOTING PROCEDURE 2

Disconnect the power supply lead to the microcircuit amplifier before repairing the power supply.

The following table gives nominal power supply voltages to be checked in the case of power supply failure.

Table 8-4. Power Supply Voltages

Location	Voltage
PIN 7 XA5	+50 V
PIN 8 XA5	+28.65 V
PIN 9 XA5	+28.0 V
PIN 13 XA4	+28 V
PIN 14 XA5	+28 V
Base A1Q1	+46.8 V
Base A1Q2	+29.4 V
Base A1Q3	+6.2 V
Base A1Q4	+6.2 V
Base A1Q5	+6.2V
Emitter A1Q1	+47.4 V
Emitter A1Q4	+5.6 V

Model 8447A

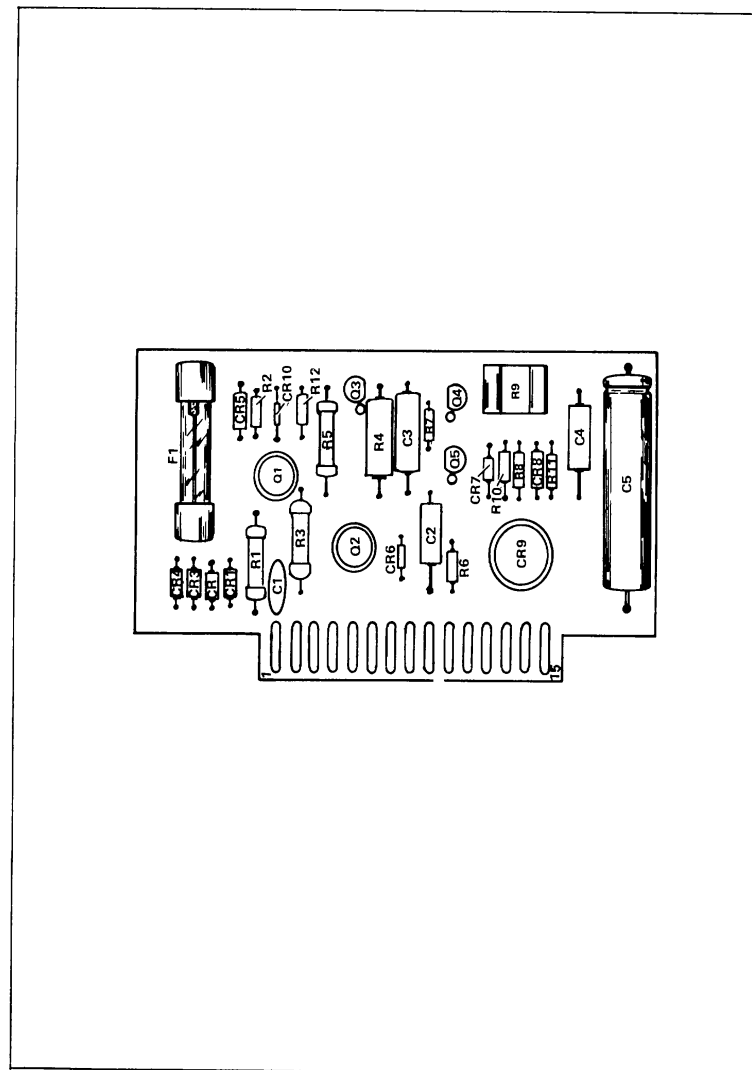

Figure 8-3. A1 Power Supply Component Location

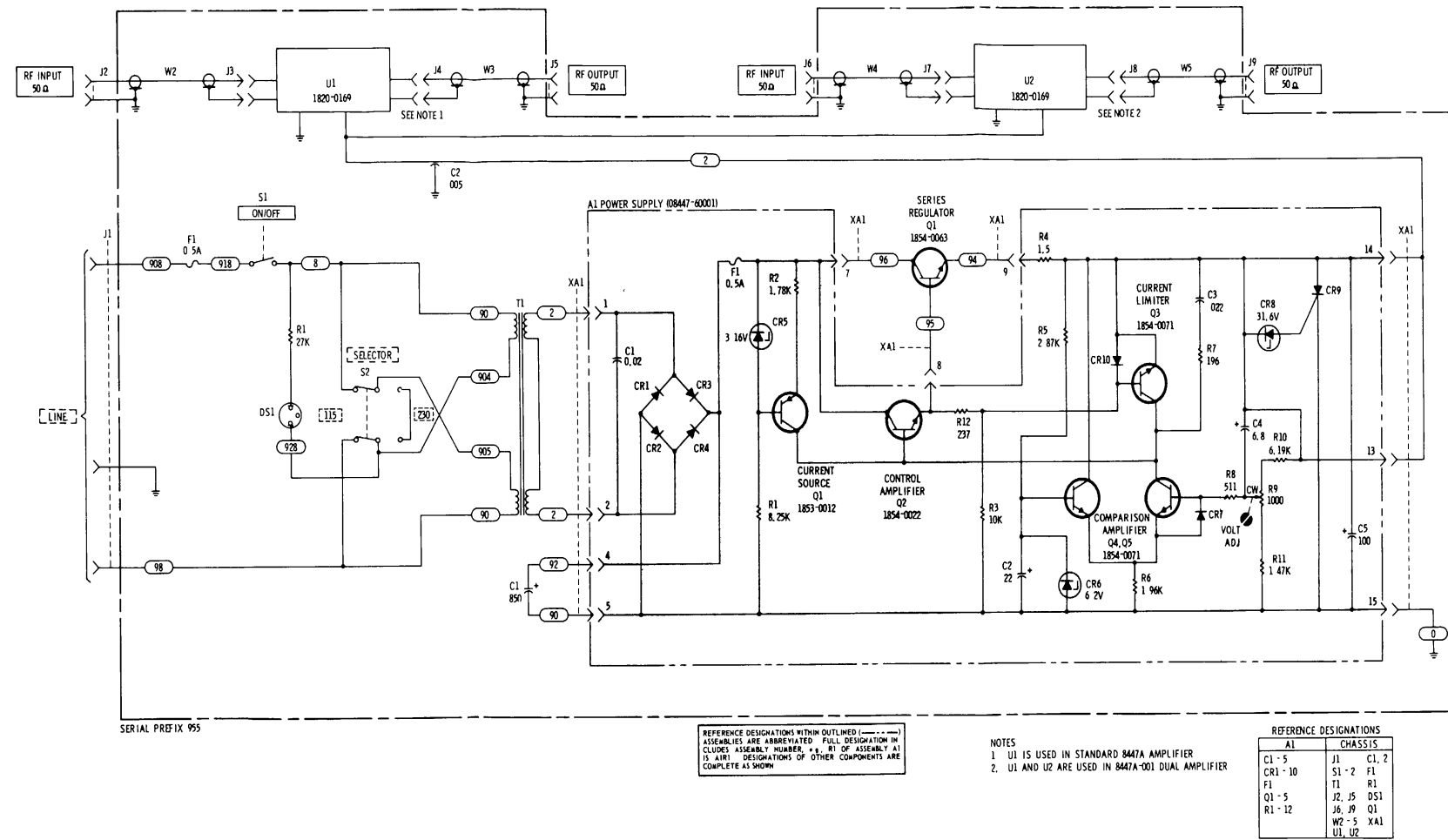

Figure 8-4. A1 Power Supply Amplifier

8-9/(8-10 blank)

APPENDIX A

MAINTENANCE ALLOCATION CHART

Information pertaining to Maintenance Allocation Chart (MAC) will be furnished at a later date.

A-1/(A-2 blank)

By Order of the Secretary of the Army:

Official:

JOHN A. WICKHAM, JR.
General, United States Army
Chief of Staff

R. L. DILWORTH
Brigadier General, United States Army
The Adjutant General

Distribution:

To be distributed in accordance with DA Form 12-32, Operator, Organizational, Direct Support and General Support Maintenance requirements for the PATRIOT Missile System.

RECOMMENDED CHANGES TO EQUIPMENT TECHNICAL PUBLICATIONS

SOMETHING WRONG WITH PUBLICATION



*THEN...JOT DOWN THE
DOPE ABOUT IT ON THIS FORM.
CAREFULLY TEAR IT OUT, FOLD IT
AND DROP IT IN THE MAIL.*

FROM: (PRINT YOUR UNIT'S COMPLETE ADDRESS)

DATE SENT

PUBLICATION NUMBER

PUBLICATION DATE

PUBLICATION TITLE

BE EXACT PIN-POINT WHERE IT IS

PAGE
NO.

PARA-
GRAPH

FIGURE
NO.

TABLE
NO.

IN THIS SPACE, TELL WHAT IS WRONG
AND WHAT SHOULD BE DONE ABOUT IT.

PRINTED NAME, GRADE OR TITLE AND TELEPHONE NUMBER

SIGN HERE

TEAR ALONG PERFORATED LINE

